

One pair of rackmount rails designed for the rear of the 4U support base of LWBR wall-mount racks provide rear support for a rackmount UPS (2U).

**FEATURES**

- For use with LWBR 4U base
- Certified US Steel, 11-gauge
- 1.75 in. x 1.40 in. x 7.00 in.
- Punched 10-32 on E.I.A spacing
- Mounting hardware included
- Made in the U.S.A.

**A&E SPECIFICATIONS**

The rack shall include Lowell Model LWBR-BRR4 rail kit, which shall feature two 14-gauge certified US steel rackmount rails. Featuring punched 10-32 holes on E.I.A spacing, the rails are made for the LWBR Series 4U base providing rear support for rackmount UPS (2U). Each rail shall measure 1.75 in. x 1.40 in. x 7.00 in.

**TECHNICAL DRAWINGS**

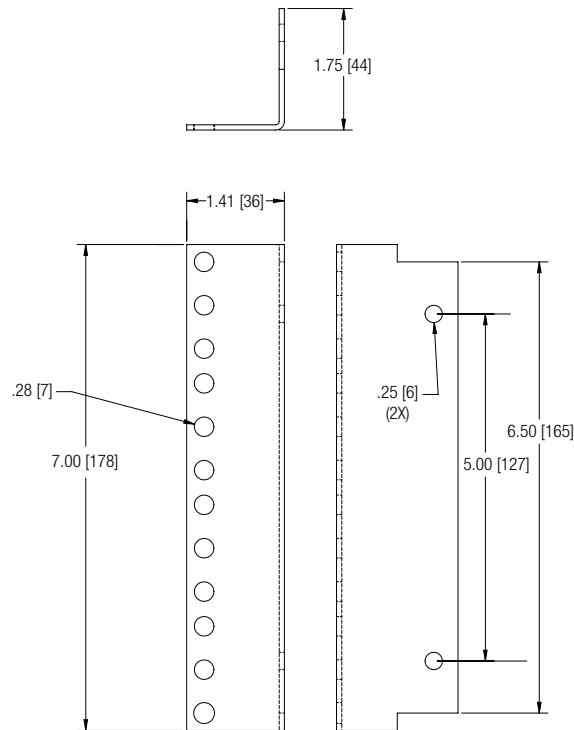

**SERIES OVERVIEW**

Model No.	Description	RU	Height	Width	Total Depth
LWBR-BRR4	Rear rackmount rail kit for LWBR Series base.	4	7.00 in.	1.41 in.	1.75 in.

