

2U x 20"D tilt-out bay holds equipment vertically
additional 3U panel space (above)

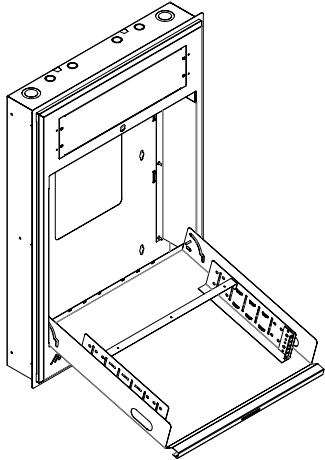

Wall-mount rack with two bays. Remove the top panel to utilize the 3U upper bay. The lower (main) bay tilts down when opening to operation or service position.



features.

- **Panel Space:** 2U x 20"D tilt-out bay
3U removable panel (above)
- **Height:** 35.00" (rack), 36.20" (trim plate)
- **Width:** 24.50" (rack), 25.70" (trim plate)
- **Depth:** 5.19"
- **Description:** Tilt-open wall-mount rack is ideal for 19"W amplifiers, small mixers, PA systems, or consumer electronics, mounting equipment so it's stored vertically. Utilize the upper bay by removing the solid panel and replacing it with a control panel or accessories.
- **Construction:**
 - Certified U.S. steel frame with beveled edges. Neutral Network Grey wrinkle powder epoxy finish.
- **Tilt-out Bay (2U x 19"W x 20"D):**
 - Mounts equipment vertically. First space 18"D max., second space 20"D max.
 - To open, lift integral handle and lower main compartment to positive stop for equipment operation (12°) or servicing (105°). *Note that some equipment may require lowering to the horizontal position for proper operation.*
 - Adjustable Rails: 1 pair of 11-gauge steel 10-32 threaded rails on E.I.A. spacing.
 - Clamping bracket helps secure equipment
 - Integral formed handle
 - Vents in front and base
 - Center key lock secures this bay
 - Includes 1-gang E.O. box in base for convenient connection to AC power
 - Includes DIN rail in base
- **Removable 3U Panel:**
 - Remove the blank panel to utilize this space. This bay does not have a door, so it's ideal for quick access to a control panel.
 - Fixed Rails: 1 pair of 11-gauge steel 10-32 threaded rails on E.I.A. spacing.
- **Cable Management:**
 - Combination EKO's for conduit in top and base (1/2"–3/4", 1"–1-1/2")
 - Multiple bridge lances
 - Rear cutout accommodates wall obstructions
- **Hardware:** Pilot point screws with captive washers.
- **Installation:**
 - Ships ready to install.
 - Mounts on standard 16" centers
 - For recessed installation in brick, concrete block or stud wall.
- **Compliance:** EIA/TIA compliant. RoHS compliant.
- **Load Capacity:** 100 lbs.
- **Optional:**
 - **Panel #D8P-ID-3:** 3U panel with rear lacing flange and Pocket-ID window will accept up to eight 1-gang devices.

a&e specifications.

The recessed wall-mount rack with tilt-out operation shall be Lowell #LTR-220R, which shall provide 2U panel space for vertical mounting of 19 inch wide equipment in the tilt-out bay (first panel space 18"D max., second panel space 20"D max.). Overall rack dimensions shall be 35.00"H x 24.50"W x 5.19"D. The trim plate shall measure 36.20"H x 25.70"W. The rack shall feature vents in front and base, compound knockouts in top and base, and a center rear cutout to accommodate wall obstructions or cables. The tilt-out bay shall include 1 pair of adjustable mounting rails tapped 10-32, a clamping bracket to help secure equipment, DIN rail and 1-gang E.O. box in base. It shall secure with

a center key lock. The rack shall also feature a 3U upper panel that can be removed to mount an optional control panel or shallow equipment (horizontally). The rack shall be manufactured in the U.S.A. with certified U.S. steel, beveled edges, and Network Grey wrinkle powder epoxy finish. The assembly shall have a load capacity of 100 lbs.

- **Options:**
 - The rack shall include a 3U x 19"W punched panel to mount one-gang devices, #D8P-ID-3.

LTR series summary

Model No.	Removable Panel (horizontal mount)	Tilt-out Bay (vertical mount)	Mounting Type	Rack Height	Rack Depth	Rack Width	Trim Plate* Height	Trim Plate* Width
LTR-220R	3U	2U	recessed	35.00 [889]	5.19 [132]	24.50 [622]	36.20 [919]	25.70 [653]
LTR-320R	3U	3U	recessed	35.00 [889]	6.94 [176]	24.50 [622]	36.20 [919]	25.70 [653]
LTR-420R	3U	4U	recessed	35.00 [889]	8.13 [207]	24.50 [622]	36.20 [919]	25.70 [653]
LTR-220S	3U	2U	surface	35.00 [889]	5.13 [130]	24.50 [622]	---	---
LTR-320S	3U	3U	surface	35.00 [889]	6.88 [175]	24.50 [622]	---	---
LTR-420S	3U	4U	surface	35.00 [889]	8.07 [205]	24.50 [622]	---	---

* Trim plate is for recessed models only
Dimensions shown in inches and [mm]; 1U = 1.75"



