

12" 150W coaxial loudspeaker #IM12P-TS100-3SW

ships ready for installation

features 12" 150W coaxial driver & 70V 100W transformer



Includes:

- 12 inch coaxial driver
- 70V 100W transformer
- Steel enclosure (3 cu.ft.) w/forged eyebolts
- White grille



features

- **Description:** Ready-to-install high performance loudspeaker provides quality sound distribution of foreground or background music in all kinds of commercial venues—it's ideal for high ceiling/high energy applications like clubs and bars, sporting facilities, concourses, hotel ballrooms, transportation terminals, convention centers, and exhibit halls. The rectangular i-Mount is designed to hang, bolt, or suspend and is suitable for open ceilings or recessed applications.
- **Driver (#12P150):**
 - 12" (8 ohm) 150W driver with robust motor structure, 38 oz. magnet, 2 in. voice coil and coaxially mounted high frequency compression driver for high power handling with excellent efficiency.
 - A steel plate is mounted over the driver to protect it during shipping and installation. Remove the plate to access the transformer tap selector and mount the grille.
 - See the spec sheet for driver #12P150 for more information.
- **Transformer (#TLS-10070):**
 - 70V 100W transformer for superior music fidelity in 70V distributed applications has a screwdriver-adjustable tap selector switch accessible through an opening in the grille.
 - Part of Lowell's 20/20 AudioVision™ line, the transformer offers true 20Hz-20kHz performance with full frequency response and high power handling to allow the speaker to operate at full potential while providing a stable load to the amplifier. The transformer allows a distributed speaker system to sound imperceptibly the same as a transformerless direct-to-voice-coil system but with easier wiring, reduced labor, and less expense.
- **Enclosure:**
 - The 3 cu.ft. precision-formed U.S. steel enclosure measures 23.94" x 18.19" x 12". It features anti-vibration ribs, soundstop board, 1-1/2" thick premium acoustic lining, and black powder epoxy finish. *Note: For plenum space with limited height a 2 cu.ft. enclosure is also available. Call for model no. and pricing.*
 - Pre-mounted (1/4"–20) forged eyebolts, are screwed into mounting nuts for secure suspended installation (flyware by others). Eyebolts can be removed for threaded rod or strut-mount applications.
 - Externally accessible connections are terminated through a 4" x 4" flush cover plate.
- **Grille:**
 - Perforated steel grille with white powder epoxy finish is ideal for applications where the speaker is suspended in a tile, sheetrock or plaster ceiling.
 - 15.25" square x 0.375"

IM Series Summary

Model No.	Driver	Transformer	Enclosure	Grille	Std.Ctn. Pack	Ctn.Wt. (lbs.)
IM12Q-TS100-3SW	12" 250W coaxial	70V 100W	Black 3 cu.ft.	White 15.25" sq.	1	75
▶ IM12P-TS100-3SW	12" 150W coaxial	70V 100W	Black 3 cu.ft.	White 15.25" sq.	1	63
IM8P-TS100-2SW	8" 100W coaxial	70V 100W	Black 2 cu.ft.	White 15.25" sq.	1	47
IM8A-TS32-2SW	8" 50W coaxial	70V 32W	Black 2 cu.ft.	White 15.25" sq.	1	47

Note: Black, white, and custom color grilles and enclosures are available upon request. Additional charges and/or delivery times may apply.



a&e specifications

The speaker for suspended installation shall be Lowell iMount® Model IM12P-TS100-3SW which shall feature a 12 in. (8 ohm) 150W driver mounted in a black steel acoustic enclosure (23.937 in. x 18.19 in. x 12 in., 3 cu.ft. volume) with anti-vibration ribs, soundstop board, 1-1/2 inch thick acoustic lining, and forged 1/4 inch-20 eyebolts screwed into mounting nuts for suspended installation using fly-ware by others. It shall include a perforated steel architectural grille with white finish. System frequency response shall be 49Hz–10.1kHz (±6dB) and 45Hz–20kHz (±7.7dB) with average sensitivity of 96.1dB @1W/1M. Dispersion shall be 65 degrees conical @2kHz octave measured 6dB down. The system shall have a driver with 38 oz. magnet, 2 in. voice coil, and coaxially mounted high frequency compression driver. The speaker shall include a wired 70V 100W transformer with screwdriver-adjustable tap selections accessible behind the white steel grille.

technical drawings

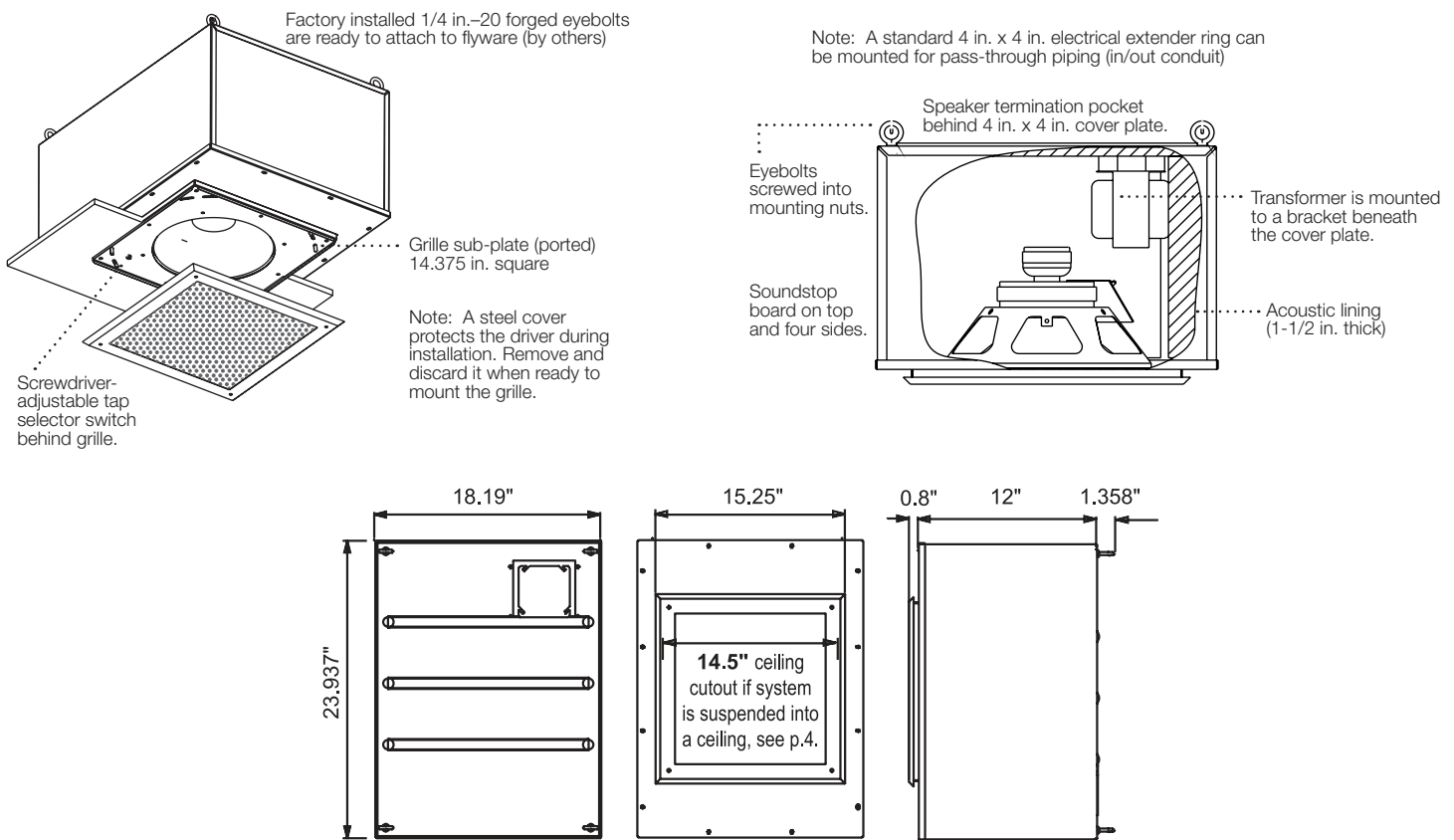

technical specifications

System Specifications: #IM12P-TS100-3SW

Driver No.	Driver Rating	Driver Size	Driver Type	Enclosure Volume	Enclosure Dimensions	System Response	System Dispersion*	System Sensitivity (SPL)**
12P150	150W (8 ohm)	12 in.	Direct radiator LF Coaxial compression HF	3 cu.ft.	23.937 in. x 18.19 in. x 12 in.	49Hz–10.1kHz (±6dB) 45Hz–20kHz (±7.7dB)	65 degrees conical @2kHz octave (-6dB)	96.1dB Avg @1W/1M 117.9dB Max @150W/1M

* For help in determining speaker spacing, go online (www.lowellmfg.com) and see the paper, "Distributed Speaker Spacing for the Integrator." An online calculation tool—the Speaker Spacer—is also available.
 ** Maximum sensitivity is calculated based on power rating and measured sensitivity.

Transformer Specifications: #TLS-10070

Transformer No.	Primary Voltage	Power Rating	Primary Taps	Secondary Impedance	Core Size	Insertion Loss	Frequency Response
TLS-10070	70V	100W	100, 64, 32, 16W	8, 4 ohms	1.375 x 1.75 in.	.6dB	20Hz–20kHz (±1dB)

* Lowell's 20/20 AudioVision™ series of transformers offer true 20Hz–20kHz performance for full fidelity audio in distributed applications.

SPL vs. FREQUENCY (1W/1M, full space, on-axis)

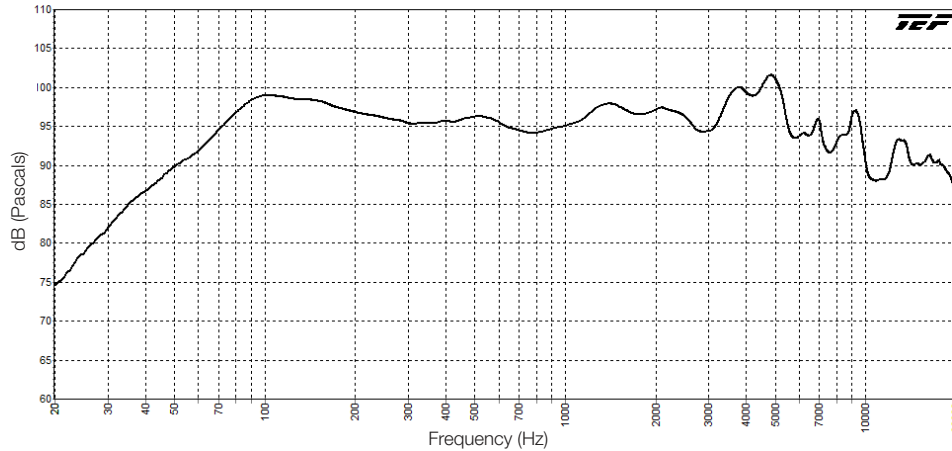

IMPEDANCE

See driver spec sheet for specifications and impedance curve.

Tap Voltage	Transformer Tap Power Value	Theoretical Tap Impedance	Tap Impedance Measured with 1kHz Impedance Meter
70 V	16W	312.5 ohms	560
70 V	32W	156.25 ohms	280
70 V	64W	78.125 ohms	140
70 V	100W	50 ohms	90

POLAR DATA (full space)

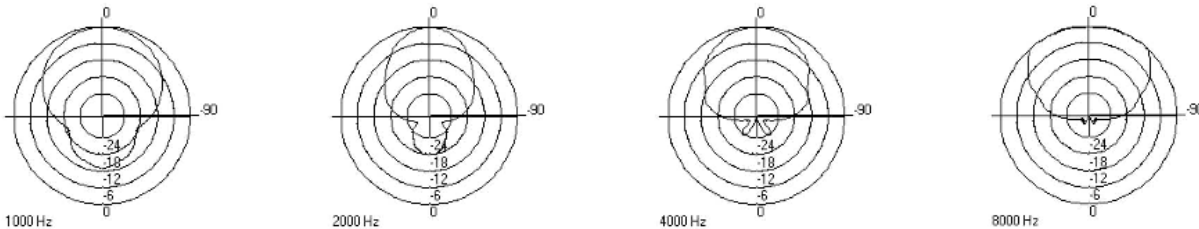

TEST METHODOLOGIES

Lowell iMount® speaker systems are thoroughly tested to provide specifiers and contractors with accurate data. Test equipment includes the GoldLine TEF-20 analyzer.

- **Power Handling:** specification is based on E.I.A. Standard RS-426B.
- **Frequency Response:** describes the usable response range defined by a ± 6 dB window, which is useful in predictive engineering calculations.
- **Sensitivity:** is a computer calculation of the log average sound pressure level (SPL) over the entire engineering bandwidth as given in the Frequency Response (± 6 dB).
- **Maximum SPL:** is calculated based on the Power Handling and the measured log average Sensitivity where $\text{Maximum SPL} = (\text{Sensitivity @ 1W1M}) + 10 \log (\text{Power Handling})$.
- **Dispersion Angle:** is defined as the angle of coverage that is no more than 6dB down from the on-axis value averaged over the 2kHz octave band. Since speech intelligibility is dependent upon the 2kHz octave, this specification is useful in designing voice reinforcement and music systems that provide even coverage and intelligibility. The polar plots illustrate how the system performs when hung in free space (360°) or half-space (180°) in the case of a recessed speaker.

installation & wiring

MOUNTING NOTE: The speaker system must be mounted in accordance with local, state, Federal and industry regulations. It is the owner and/or user's responsibility to evaluate the reliability of any rigging/support method for their application. Rigging/installation should be carried out only by experienced professionals.

SPEAKER INSTALLATION:

There are three basic ways to install this speaker system:

Note: The contractor shall employ the services of a qualified certified rigger for the installation of this product. Only load-rated hardware with a design factor of at least X5 should be used to suspend this product. The rigging system design is solely the responsibility of the installing contractor and the rigging design should be reviewed and certified by a professional structural engineer.

- 1). Suspended in Open Area (Fig. 1):** Hang the system using the installed forged eyebolts and flyware (by others) so that it is suspended in an open area.
- 2). Suspended into Rigid or Tile Ceiling (Fig. 2):** Hang the system using the installed forged eyebolts and flyware (by others) so that it is suspended into a rigid or tile ceiling.
- 3). Hard Mount (not pictured):** Hard mount or "rear anchor" the system to structural members or unistrut using bolts (by others).

WIRING:

1). Typical Wiring Method (Fig. 3):

Remove the 4 in. x 4 in. cover plate located on the rear of the enclosure. Remove the knockout plug in the plate and install a UL Listed conduit connector or cable clamp as appropriate. Connect the field signal wiring to the two conductors sticking out of the rear of the enclosure (red is positive, black is negative). Push the connections and all excess wire into the enclosure and to one side of the transformer bracket. Re-attach the cover plate to the enclosure.

2). Alternate Wiring Method — in/out conduit (Fig. 4):

Remove the 4 in. x 4 in. cover plate located on the rear of the enclosure. Install an approved 4 x 4 extender ring, attaching it to the mounting holes where the cover plate was secured. Select wiring entry positions on the side of the extender ring and remove the corresponding knockouts. Install conduit connectors and secure conduit. Make wiring connections (red is positive, black is negative). If the unit is being installed above a ceiling, push the wiring and connectors into the enclosure and to one side of the transformer bracket.

TRANSFORMER:

• Transformer Settings (Fig. 5):

After the speaker system is installed, locate the tap selector by the speaker cone. **IMPORTANT! Before turning power on** use a screwdriver to turn the switch counter-clockwise to the lowest tap setting. Then turn the switch clockwise incrementally until you reach the setting desired. Starting at the lowest position avoids accidental selection of the wrong tap. The selector switch will still be covered when the grille is mounted.

GRILLE:

• Grille Installation:

Remove and discard the plate that protected the speaker during shipping. Mount the perforated grille over the speaker cone using 8-32 screws (provided), installing it in the holes previously used by the cover plate.

Fig. 1: Suspended in Open Area

(360 degree full space mounting.)

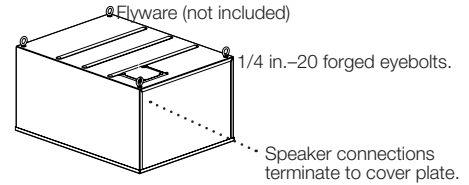

Fig. 2: Suspended into Rigid or Tile Ceiling

(180 degree half space mounting.) Note: Load support is on eyebolts, not ceiling.

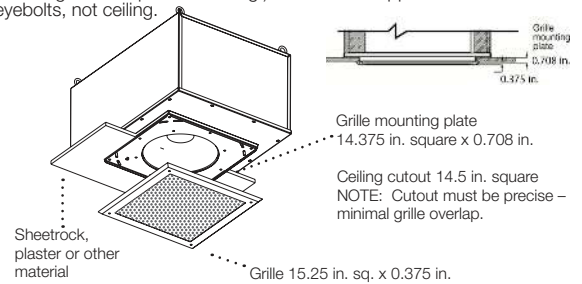
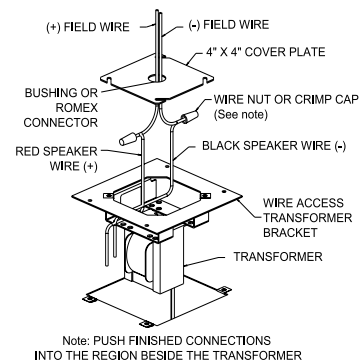
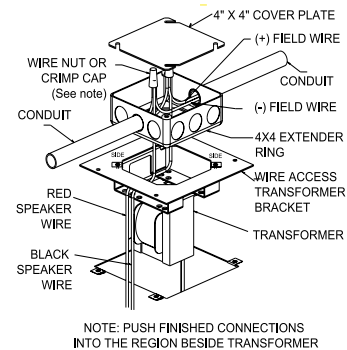

Fig. 3: Typical Wiring



Note: PUSH FINISHED CONNECTIONS INTO THE REGION BESIDE THE TRANSFORMER

Fig. 4: Alternate Wiring (conduit)



NOTE: PUSH FINISHED CONNECTIONS INTO THE REGION BESIDE TRANSFORMER

Fig. 5: Transformer Settings (100W)

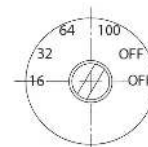

Switch Position	Transformer
1	16
2	32
3	64
4	100
5	OFF
6	OFF