



features.

- **Description:** Remote power controls can be combined with a variety of switches or sequencers for an intrinsically safe, low voltage method of controlling AC power to equipment at remote locations. Controlling power distribution without directly accessing equipment minimizes the potential for unauthorized access, while simplifying activation and deactivation of equipment.

Note: RPCs require an external trigger for activation (order separately).

- **Chassis:** The 2U steel rackmount chassis (19" x 3.5" x 2.75") with black finish features a blank front. When mounted, the outlets and terminal strip are oriented to the inside of the rack.

- **Power:**

- Power Rating: 125VAC 60Hz 15A
- Outlets: Total of eight (8) NEMA 5-15R outlets, which include 4 switched duplexes.
- Attached Cord: 6 ft. cord with NEMA 5-15P plug

- **Activation:** The (4) duplex outlets are controlled by contact closure.

- Dry Contact Closure (30V 40mA min.): Connect SPST switch, power sequencer, or independent control system with dry contact closure.

- **Origin:** Made in the U.S.A. with global components.

- **Third Party Approval:** ETL Listed to UL60065 (U.S. and Canada)

- **Installation:** The RPC is typically installed near the equipment to be controlled. Low voltage cable is run from its terminal strip to a control switch (or other control method).

- Systems can be configured with multiple RPCs controlled by a single "Maintained Closure" switch.

- Systems can also be configured with a single RPC controlled by multiple "Momentary Closure" switches and Lowell's MSM2 module (which converts momentary closure to maintained).

- **A&E Specifications:** The device for remotely controlling AC power shall be Lowell model # RPC-4CD, which shall feature a 2U steel chassis with black powder epoxy finish (19" x 3.5" x 2.75"), 125VAC 60Hz 15A power rating, (4) NEMA 5-15R duplex outlets, and a 6 ft. cord with NEMA 5-15P plug. The unit shall require an external trigger (not included) to activate switched outlets.

- **Compatible Devices:** (order separately)

- **SPST Switch (RPS Series):** Low voltage wall-mount or rack-mount switch:

- Switch with maintained closure connects directly to RPC.

- Switch with momentary closure requires Lowell conversion module #MSM2 placed between the switch and RPC.

- **Power Sequencer (SEQ Series):** A low voltage sequencer can be used with the RPC for time-delayed activation and deactivation of connected equipment. Lowell standalone sequencers will require a switch for activation, while Lowell rack-mount sequencers include a switch. See product spec sheets for information.

Ideal for Lowell switches featuring maintained closure (order separately):

- #RPSB-P Black wall plate w/rocker switch
- #RPSW-P White wall plate w/rocker switch
- #RPSW-KP White wall plate w/key switch
- #RPSB-R Rack panel w/rocker switch
- #RPSB-KR Rack panel w/key switch

RPC Series overview

Model No.	Chassis	Outlets	Input	Power Rating	Surge Suppression	External Activation Required	Connections
RPC-15	Standalone	NEMA 5-15R (2)	6' attached cord	125VAC 60Hz 15A	---	Dry contact closure	Terminal Strip
RPC-15-S	Standalone	NEMA 5-15R (2)	6' attached cord	125VAC 60Hz 15A	Yes	Dry contact closure	Terminal Strip
RPC-15-SCD-RJ	Standalone	NEMA 5-15R (2)	6' attached cord	125VAC 60Hz 15A	Yes	Dry contact closure or VT*	TS or RJ45
RPC-15-U	Standalone	IEC C13 (2)	6' detachable cord (2)	100-240VAC 50/60Hz 15A	---	Dry contact closure or VT*	Terminal Strip
RPC-20-CD	Standalone	NEMA 5-20R (2)	6' attached cord	125VAC 60Hz 20A	---	Dry contact closure or VT*	Terminal Strip
RPC-20-SCD	Standalone	NEMA 5-20R (2)	6' attached cord	125VAC 60Hz 20A	Yes	Dry contact closure or VT*	Terminal Strip
RPC-20-SCD-RJ	Standalone	NEMA 5-20R (2)	6' attached cord	125VAC 60Hz 20A	Yes	Dry contact closure or VT*	TS or RJ45
RPC-3N1	Standalone	NEMA 5-15R (8)	6' attached cord	125VAC 60Hz 15A	---	Dry contact closure	Terminal Strip
▶ RPC-4CD	Rackmount	NEMA 5-15R (8)	6' attached cord	125VAC 60Hz 15A	---	Dry contact closure	Terminal Strip
RPC-20-HW	Standalone	NEMA 20A (2)	6' flexible whip	125VAC 60Hz 20A	---	Dry contact closure or VT*	Terminal Strip
RPC-20-SHW	Standalone	NEMA 20A (2)	6' flexible whip	125VAC 60Hz 20A	Yes	Dry contact closure or VT*	Terminal Strip
RPC-30-SHW	Standalone	Twistlock 30A (1)	6' flexible whip	125VAC 60Hz 30A	Yes	Dry contact closure or VT*	Terminal Strip

* VT indicates the RPC can also accept a voltage trigger provided by an independent control system.



CONNECTIONS:

Wiring Note: Connections to switch are made via 3-conductor cable.

22 gauge max distance is 6,600 ft. or 1.25 miles; 18 gauge max. distance is 17,160 ft. or 3.25 miles.

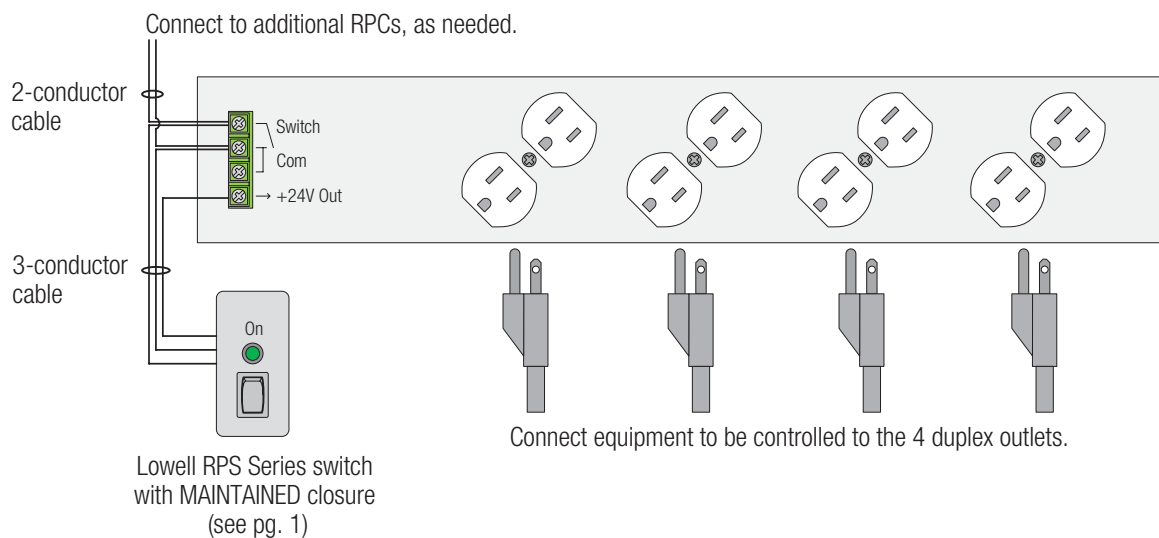

RPC TYPICAL CONTROL METHODS (low voltage, limited current Class 2 wiring):

EXAMPLE 1: SPST switch with MAINTAINED closure.

See Lowell RPS Series models listed on pg. 1.

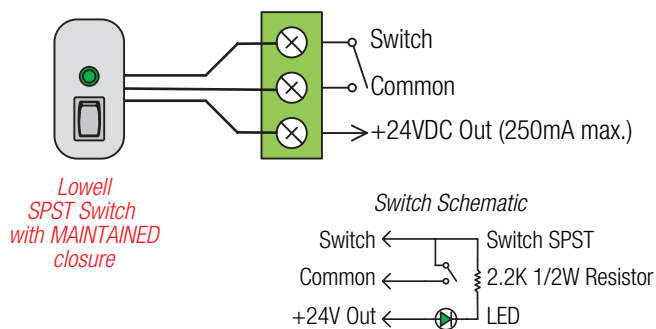

EXAMPLE 2: Sequencer or Control System.

Lowell SEQ Series sequencer or control system by others.

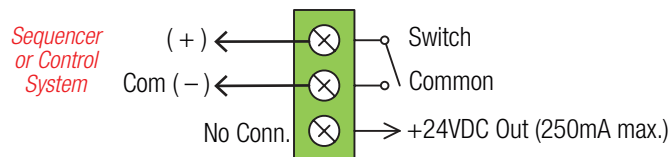

Follow polarity indicators, if any, on sequencer/controller (min. rating: 24V, 40mA)

ON = connection applied (closed)
OFF = connection removed (open)

EXAMPLE 3: Fire Alarm Panel Interface.

Interface with normally closed (N.C.) contact from Fire Alarm Panel.

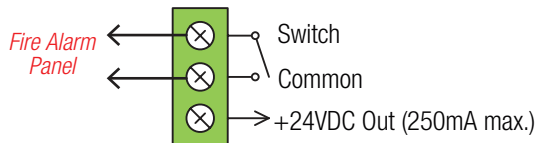

Application Example: The RPC provides power to a music/paging system in a retail store. The Fire Alarm Panel forces music/paging system OFF so alarm can be heard.

