



Model No. WB-8-6 Grille

Steel ceiling grille for use with a 6.5" driver features a clean contoured edge and an economical cost making it a popular choice for offices, schools, medical facilities and commercial applications of all kinds.

Features

- Precision formed from single piece of 22-gauge steel with a perforated center and beveled edge.
- White powder epoxy finish
- 8-32 x 1" welded studs with palnuts for concealed mounting of an E.I.A. 6.5" speaker.
- Four white 8-32 x 1-1/2" Phillips-head screws for attaching a speaker/grille assembly to a backbox or mounting ring (order separately).
- Features the same diameter as Lowell's 8" grille Model WB-8, which allows it to mount to the same backboxes. This allows the contractor to standardize on one backbox while using 8" and 6.5" speakers in different areas of a project.

A & E Specifications

The grille for use with a 6.5" driver shall be Lowell Model WB-8-6. It shall be one-piece 22-gauge steel reinforced with a peripheral flange of 60 degrees. The diameter shall be 12.875" with a shallow mounting projection of 0.25". Model WB-8-6 shall include welded studs for mounting specified 6.5" speaker. It shall feature four 0.25" holes spaced at 90 degree intervals on a 11.25" bolt circle for mounting the specified backbox or mounting ring. The grille shall be finished in white powder epoxy and include four white 8-32 x 1-1/2" Philips-head screws for backbox mounting.

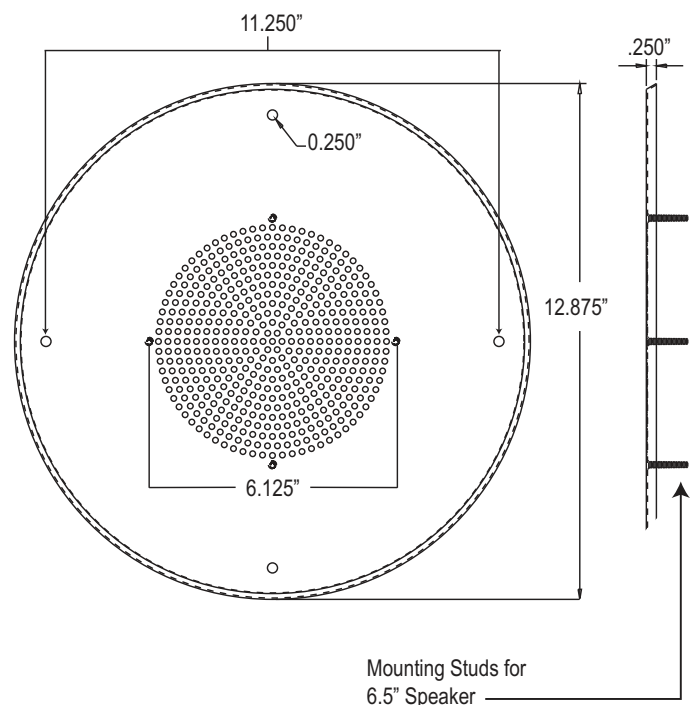



Heard Everywhere Since 1947

Companion Accessories (order separately)

Grille Model No.	Size	Mtg. Provisions	Backbox or Mtg. Ring Choices (Choose one, plus tile bridge or rails if required)	T-Bridge or Rails (if required for suspended ceiling)
WB-8-6	12.875" dia.	4 screws	CP87, CP810, DX108 XCP87, XCP810, RF871	LBS8-CP or SS series rails LBS8 or LBS8-R1

Choose one backbox or mounting ring, plus tile bridge or rails if required for suspended ceiling. Note: These accessories sized for an 8" driver also accept the WB-8-6 grille with a 6.5" driver.

<i>Model No.</i>	<i>Size</i>	<i>Features</i>
Backboxes		
CP87	11.938"Dia. x 6.687"D	Extended lip for sheetrock + batting
CP810	11.938"Dia. x 10.063"D	Extended lip for sheetrock + batting
DX108	15"Dia x 10.125"D	1 cu.ft., Extended lip + batting
RF871	10.063"Dia. x 6.688"D	Retrofit w tension brkt.
XCP87	10.063"Dia. x 6.687"D	Flat flange for tile ceiling + batting
XCP810	10.063"Dia. x 10.063"D	Flat flange for tile ceiling + batting
Mounting Rings		
PR8-1624	13.25" Dia with ears	Extended lip for sheetrock plus mounting ears for 16" & 24" studs, steel
RMP8	13.813" Dia.	Plastic - use for retrofit
Tile Bridges		
LBS8-CP	23.75"L	Requires noted backbox
LBS8	23.75"L	8.5"SQ opening with screw or Twist n' Lock backbox mounting
LBS8-R1	23.75"L	10.75"Dia opening with screw or Twist n' Lock backbox mounting
Channel Rails		
SS-24	23.75"L	
SS-30	30"L	
SS-48	47.75"L	