



Front frame pivots down for access



features.

- **Panel Space:** 8U or 14.00" [356]
- **Overall Height:** 16.25" [413]
- **Overall Depth:** 12.00" [305]
- **Usable Depth:** 11.97" [304]
- **Overall Width:** 19.30" [490] (allow 21" for wing nuts)
- **Description:** Ideal platform for installing voice and data equipment, patch panels, routers, hubs, and network switches to create a structured, organized cabling system.
- **Construction:** Certified U.S. steel, 16-gauge frame with black semi-gloss powder epoxy finish.
- **Front:** Hinged panel-mounting frame pivots to 90 degrees with an absolute stop to provide access to equipment for punch-down interconnects while in the fully open position. Optional front panel can be added if the optional top cover is also used (order separately).
- **Rear:** Removable rear panel allows positioning over and around existing wall obstructions. Rack mounts on standard 16" centers.
- **Sides:** Vents and holes for cable management.
- **Bottom:** Vents, tie loop points, and holes for cable management.
- **Top:** Open access. Optional top cover can be added (order separately).
- **Cable Management:** Integral tie loop points on bottom and rear. Holes for cables on bottom and sides.
- **Rack Rails – 8U (fixed position):** One pair of 11-gauge steel 10-32 threaded rails on E.I.A. spacing. Black finish.
- **Hardware:** Black pilot point screws with captive washers for quick installation.
- **Compliance:** EIA/TIA compliant. RoHS compliant.
- **Load Capacity:** 60 lbs. [27 kg]
- **Optional:**
 - Top cover (#PFR-TC12)
 - Front panel (#FP8), requires top cover

a&e specifications.

The EIA/TIA compliant 19" wall-mount rack shall be Lowell #PFR-812 with overall dimensions of 16.25"H x 12.00"D x 19.30"W; usable height of 8 rack units, and usable depth of 11.97". The rack shall mount on standard 16" centers. Rack construction shall be certified U.S. steel with 16-gauge frame and black semi-gloss powder epoxy finish. It shall have an open back with removable panel to fit around wall obstructions, base with vents and cable openings, and integral tie loop points. Sides shall have vents and holes for cable management. Open front shall include one pair fixed-position 8U rails tapped 10-32. The front panel-mounting frame shall pivot down to an absolute stop at 90 degrees, providing access to equipment for punch-down interconnects while in the fully open position. The rack shall be manufactured in the U.S.A. with load capacity of 60 lbs.

Optional

- The rack shall include a steel top cover with black finish, #PFR-TC12.
- The rack shall include a steel front panel with black finish, #PFR-FP8.

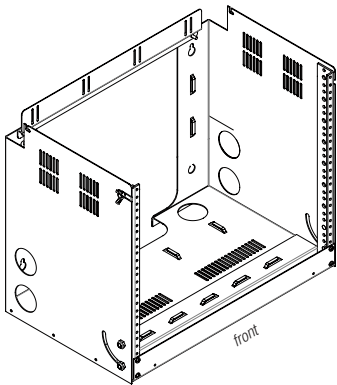

PFR series summary

Model No.	Rack Units	Overall Depth	Usable Depth	Overall Height	Overall Width	Front Frame Pivot-Down	Load Capacity	Fixed Rails
PFR-46	4 U	6.00 [152]	5.97 [152]	9.25 [235]	19.30 [490]*	90 degrees	30 lbs [13 kg]	1 pr
PFR-66	6 U	6.00 [152]	5.97 [152]	12.75 [324]	19.30 [490]	90 degrees	30 lbs [13 kg]	1 pr
PFR-612	6 U	12.00 [305]	11.97 [304]	12.75 [324]	19.30 [490]	90 degrees	40 lbs [18 kg]	1 pr
▶ PFR-812	8 U	12.00 [305]	11.97 [304]	16.25 [413]	19.30 [490]	90 degrees	60 lbs [27 kg]	1 pr
PFR-818	8 U	18.00 [457]	17.97 [456]	16.25 [413]	19.30 [490]	90 degrees	60 lbs [27 kg]	1 pr

*Allow 21" width for wing nuts.
Rack dimensions (rounded) – inches and [mm]; 1U = 1.75"

