

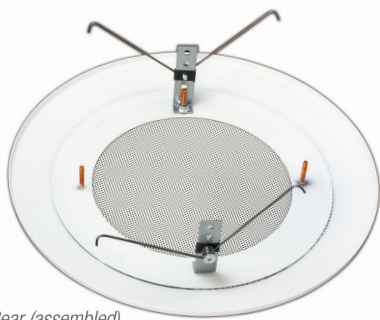

Front



Rear (assembled)



Torsion grille with contoured outer ring presents an attractive solution for specifications requiring ceiling speakers without visible mounting hardware. Welded studs and spring-loaded torsion brackets mount to torsion receptacles in compatible enclosures. The grille is ideal for offices, hotels, airports, retail space, professional buildings, and dining establishments.

### FEATURES:

- **Construction:** 20-gauge steel outer ring with a welded steel mesh center, inner ring with welded speaker studs, and white powder epoxy finish.
- **Overall Dimensions:** 12.5" diameter
- **Mounting Projection:** 0.75"
- **Speaker Stud Circle:** 7.625" diameter
- **Hardware (included):**
  - (4) 8-32 x 3/4" welded studs with nuts
  - (2) Torsion brackets (with 4 holes for depth adjustment) and spring devices (with shoulder bolt and clip) to mount to torsion receptacles in specified enclosures.
- **Hardware (included):**
  - (4) 8-32 x 3/4" welded studs with nuts to mount an 8" speaker
  - (2) Easy-install torsion brackets with spring devices allow the speaker/grille assembly to mount to torsion receptacles in compatible enclosures. Includes shoulder bolts/clips to install the two spring devices (select 1 of 4 bracket holes for depth adjustment).
- **Installation:** The torsion grille is designed to support a speaker/transformer/grille weight up to 3.5 lbs. Heavier assemblies will require the speaker/xfmr to be direct-mounted (screwed) to the inner flange of a Lowell IX Series enclosure, after which the the non-loadbearing torsion grille can be mounted to the enclosure.
  - **8" Speaker/xfmr assembly weighing less than 3.5 lbs. — includes most Lowell speaker/xfmr assemblies with 5–10oz. magnet and 4–8W transformer:** Place the speaker/xfmr assembly on the grille's welded studs, then place the two torsion devices on studs (opposite each other). Attach the speaker and torsion devices with the nuts provided. The assembly is then ready to mount to a compatible enclosure equipped with torsion receptacles.
  - **8" Speaker/xfmr assembly weighing more than 3.5 lbs. — includes all speaker/xfmr assemblies with Lowell driver model 8A50:** The speaker/xfmr assembly must be screw-mounted directly to a Lowell IX Series enclosure, which has an inner speaker mounting flange and torsion receptacles. After the speaker/xfmr assembly is mounted to the enclosure, the non-loadbearing grille with torsion devices can be mounted to the torsion receptacles in the enclosure.

### COMPATIBLE COMPONENTS (order separately):

*Note: Grilles are designed to work with speakers, enclosures, and mounting accessories listed on this specification sheet. Using the grille to install speakers without a metal enclosure may not meet the requirements of all local and national electrical and building codes. The installer should request approval of the installation method from the Authority Having Jurisdiction (AHJ) before installing the speaker system.*

Application	Speaker	Enclosure	Mounting Aids
RECESSED in Tile Ceiling with enclosure	8" EIA	XCP84, XCP84-S, XCP87, XCP810, IX810	LBS8, LBS8-R1 (t-bridge)
RECESSED Before Drywall Installed with enclosure	8" EIA	XCP84, XCP84-S, XCP87, XCP810, IX810	PR8-1624 (rough-in bridge)
		IX810-EL	SS Series (rails)
RECESSED in Existing Drywall with enclosure	8" EIA	BME84, BME87	-----

*Note: Robust coaxial speakers, such as Lowell 8A50 or 8P100, require a large volume enclosure (greater than 4"D).*



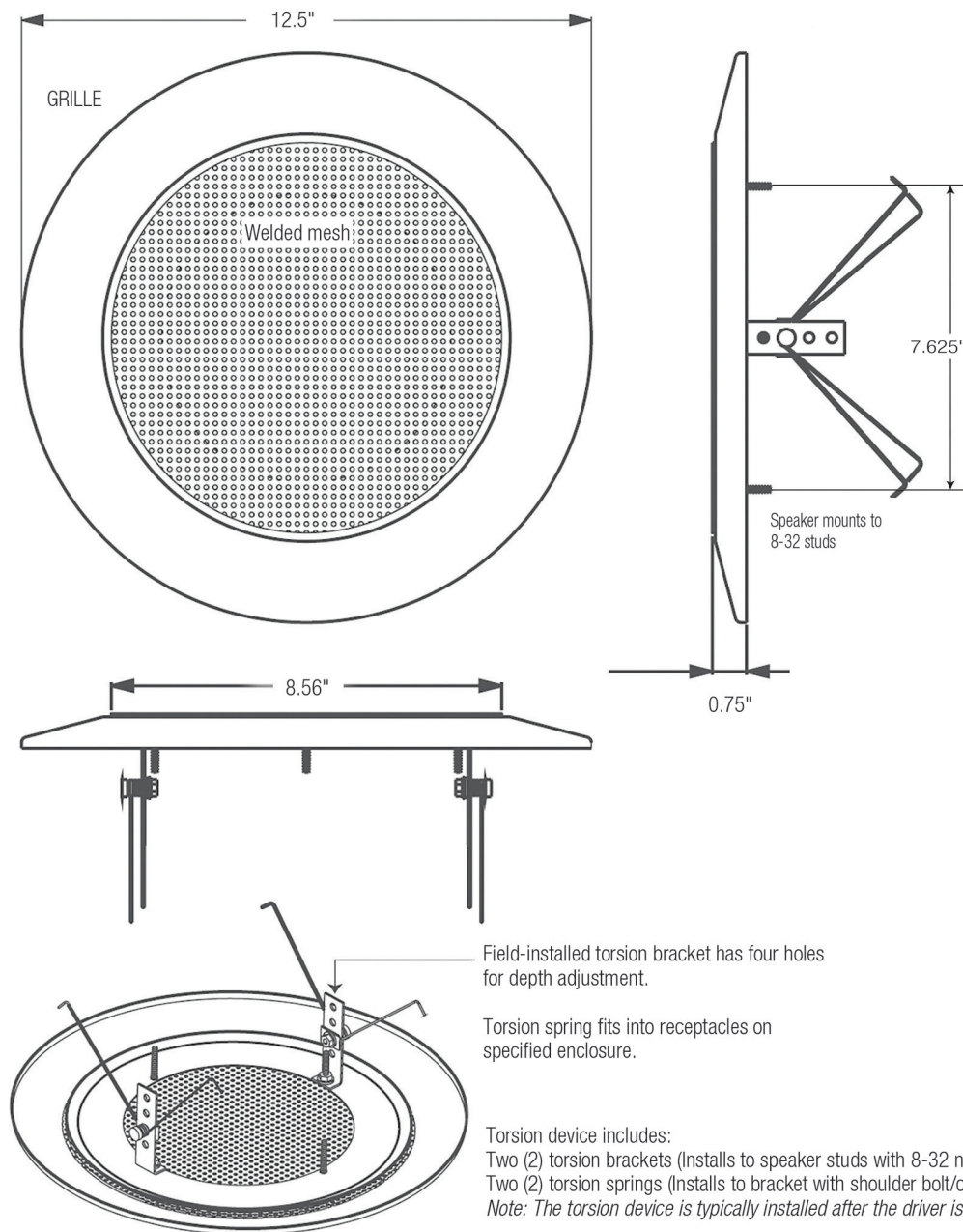

**A&E Specifications:** The grille for 8" speakers shall be Lowell model CN-8M, which shall have an outer ring made from 20-ga. steel, a welded steel mesh center, and white powder epoxy finish. Grille diameter shall be 12.5" with mounting projection of 0.75". The grille shall include welded studs with nuts, two torsion bracket/spring devices and installation accessories to mount to specified mounting ring or enclosure with torsion receptacles. The torsion/bracket method shall be adjustable for varied ceiling depths. Speaker/transformer/grille assemblies weighing less than 3.5 lbs. shall mount to speaker studs on the grille; the grille shall install to the specified backbox using the torsion devices.

[ Eight inch speaker/transformer/grille assemblies weighing more than 3.5 lbs. shall direct/screw-mount to Lowell enclosure model IX810 or IX810-EL. The grille, without the weight of the speaker/transformer, shall then mount to torsion receptacles in the backbox. ]

*WARNING! Speaker installation should only be performed by experienced qualified professionals with knowledge of load-rated hardware and safe installation, mounting, and rigging techniques. Improperly installed equipment can result in property damage, personal injury, death, and/or liability to the installing contractor. The speaker system must be mounted in accordance with all local, state, and federal codes and regulations and the installation must conform to industry standard practices. It is the responsibility of the installer to furnish all installation hardware, rigging hardware, and safety or restraint cables to be used. Before installation, it is the responsibility of the installer to consult a licensed mechanical or structural engineer to evaluate and certify the structural integrity and safety of any mounting method and the suitability of that method to be used to mount the loudspeaker to the building structure in this particular installation. Lowell Manufacturing is not responsible for the use, misuse, misapplication, or unsafe installation of this loudspeaker product.*

