

Heard Everywhere Since 1947



with domestic & global components

Model No. LT-8A-T870-Vb 1x2 Speaker System for Tile Ceilings

These speaker products are listed for UL1480A General Signaling (Indoor Dry), UL2043 suitable for use in an air handling space, and CSA C22.2 No. 205-12 General Signaling for use in Canada.

- Includes 8" driver, transformer, 1x2 grille/subplate, volume backbox

Patented Integral T-Bar supports adjacent non-regular ceiling tile.*

Quick install pro speaker system for suspended tile ceilings features premium 8" coaxial driver, 70V transformer, 1'x2' fine perforation grille with subplate and volume backbox. The patented assembly features an integral T-bar support that quickly replaces half of a non-regular 2'x2' ceiling tile or one-fourth of a non-regular 2'x4' ceiling tile. Ideal for foreground music.



Features

- **Driver (8A50):** 8" 50W coaxial driver with 20 oz. LF ceramic magnet and 2 oz. HF ceramic magnet has a frequency response of 40Hz-19.4kHz (± 6 dB), 40Hz-20kHz (± 7.3 dB) and sensitivity of 90.6dB avg. measured 1W/1M. Provides excellent power handling and smooth sound reproduction.
- **Transformer:** 70V transformer has primary taps at 1.1, 2, 4, and 8W.
- **Grille with Subplate (1'x2'):** Fine-perforation grille is designed to provide maximum free-air space for excellent sound transmission while maintaining an unobtrusive appearance in new or existing tile ceilings. Includes an integral 2" T-bar to support neighboring non-regular ceiling tile. Quick install. White finish.
- **Volume Backbox:** 0.8 cu.ft. steel backbox with 1.5" thick acoustic lining enhances audio performance. Includes removable dual knockout wiring compartment cover plate with 1/2 in. / 3/4 in. combination knockouts. Driver leads exit through a metal clamp for fast connection—just splice connecting wires, push them inside the enclosure and tighten the clamp. Black finish. Backbox is offset to fit around plenum obstructions.



Assembly is fabricated with a restraint tab in one corner and a hole in the diagonally opposite corner for (two cable) code compliance. Use the tip of a screwdriver to bend the tab out for tie-offs.



Mounted driver and transformer

A&E Specifications

The speaker system for suspended tile ceilings shall be Lowell Model No. LT-8A-T870-Vb. The 1'x2' system shall replace half of a non-regular 2'x2' ceiling tile or one-fourth of a non-regular 2'x4' ceiling tile and shall include an integral T-bar to support adjacent ceiling tile. Each speaker system shall include a factory-mounted driver mounted to a subplate with a fine perforation steel grille finished in white powder epoxy. The driver shall be 8" coaxial with a power rating of 50W. It shall have ceramic magnet weight of 20 ozs. (LF) and 2 ozs. (HF), frequency response of 40Hz-19.4kHz (± 6 dB), 40Hz-20kHz (± 7.3 dB) and

sensitivity of 90.6dB avg. measured 1W/1M. The driver shall include a factory wired 70V transformer with primary taps at 1.1, 2, 4, and 8W. The system shall include a steel backbox (0.8 cu.ft.) with acoustic lining, removable dual knockout wiring compartment cover plate with 1/2 in. / 3/4 in. combination knockouts, and leads exiting through a metal clamp.

Driver Specifications (half space)

Driver No.	Size	Power Rating	Type	Ceramic Magnet	Frequency Response	Dispersion @2000Hz -6dB	Voice Coil Impedance	Voice Coil Diameter	Sensitivity 1W / 1M	Max SPL**	Depth	Weight
8A50	8"	50W	Coaxial	20 oz. LF 2 oz. HF	40Hz-19.4kHz (± 6 dB) 40Hz-20kHz (± 7.3 dB)	90 degrees conical	8 ohms	1.4" LF 0.53" HF	90.6dB Avg	107.6dB	3.85"	3.5 lbs.

** Calculated value 1M @ driver power rating.

Additional technical information is available on the spec sheet for driver No. 8A50

* U.S. patent no's. 7,120,269; D467,579; 7,643,647

Lowell makes every effort to provide accurate information while reserving the right to change specifications and/or improve manufacturing methods without notification.

©2016 Lowell Manufacturing Company, 100 Ingram Dr., Pacific MO 63069 | tel. 800.325.9660 | www.lowellmfg.com

Drawings

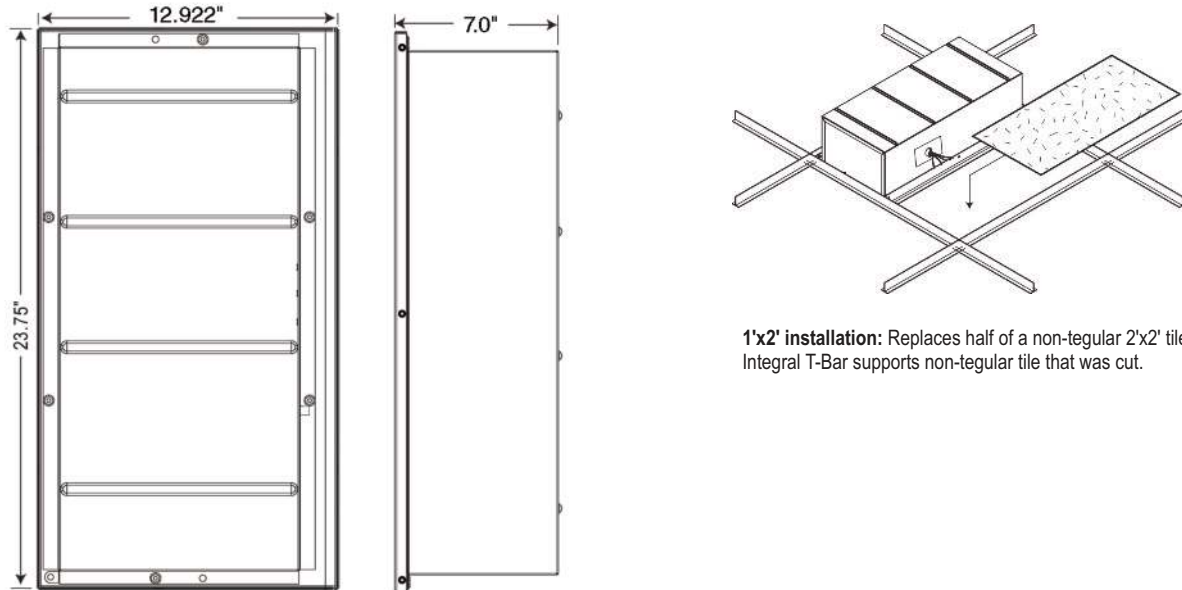

Scope of Performance & Power Tests

Lowell drivers and loudspeaker systems are tested to provide specifiers and contractors with data that reflects the performance of production products. Testing equipment includes the GoldLine TEF-20 analyzer (for performance measurements) and the LinearX LMS measurement system (for Thiele-Small Parameters).

Power Rating is tested based on EIA Standard RS-426B.

Frequency Response data is provided which is the measured frequency response range (defined by +6dB) which is useful in predictive engineering calculations.

Sensitivity (SPL) data is presented in two ways: Log Average SPL is a computer calculated log average of the SPL measured at 1 meter with 1 watt input over the stated frequency response range. Maximum SPL is calculated based on the measured log average SPL and the power rating of the speaker.

Thiele-Small Parameters for raw drivers are measured using the LinearX LMS measurement system. These parameters are useful in determining the optimum type and size of enclosure for a specific driver.

Impedance data is presented in three ways: Nominal Impedance is the generally accepted impedance for use in making comparisons with competitive products; the Impedance Curve is a graphical representation of the impedance that is measured in the lab and gives the impedance of the device over the audio frequency range; Minimum Impedance is the lowest impedance measurement at a frequency within the specified frequency response range of the speaker.

Polar Data is presented for the averaged one octave band surrounding the center frequencies of 1000Hz, 2000Hz, 4000Hz, and 8000Hz. Radial polar response curves show the relative change in sound pressure level as one moves from directly on-axis to an increasingly off-axis listening position. Since coaxial speaker drivers are symmetrical in the vertical and horizontal directions, only one set of polar plots will be presented for coaxial drivers and speaker systems incorporating coaxial drivers.

Dispersion Angles: For more information on dispersion angles visit lowellmfg.com to download the white paper "Distributed System Speaker Spacing for the Integrator" or try the online Speaker Spacer app for quick calculations.

- **Conical Dispersion** is the angle of coverage where the SPL **at an equal distance from the speaker** is no more than 6dB down from the on-axis value over the 2000Hz octave band. Conical Dispersion can be used to compare two speakers, if the conical dispersion is provided for each.
- **Linear Dispersion** is the angle of coverage where the SPL **at the average listening height** (where listeners' ears would be) is no more than 6dB down from the on-axis value over the 2000Hz octave band. Linear Dispersion is used to determine the proper speaker spacing in distributed speaker systems.