



Model No. **LT-830-BB** **1x2 Speaker System for Tile Ceilings**

- **Includes 8" coaxial driver, 1x2 grille/subplate, backbox**

Quick install speaker system for suspended tile ceilings features an 8" coaxial driver, 1'x2' fine perforation grille with subplate and backbox. The patented assembly features an integral T-bar support that quickly replaces half of a non-regular 2'x2' ceiling tile or one-fourth of a non-regular 2'x4' ceiling tile. Ideal for commercial paging and background music.

Features

- Driver (CT830A): 8" 20W coaxial driver with 12 oz. magnet, frequency response of 57Hz-14kHz (± 6 dB), 44Hz-20kHz (± 7.6 dB) and sensitivity of 97.0dB avg. measured 1W/1M.
- Grille with subplate (1'x2'): Fine-perforation grille is designed to provide maximum free-air space for excellent sound transmission while maintaining an unobtrusive appearance in new or existing tile ceilings. Includes an integral 2' T-bar to support neighboring non-regular ceiling tile. Quick install. White finish.
- Backbox (8XD4): 0.147 cu.ft. steel backbox protects driver. Speaker leads exit through a metal clamp for fast connection—just splice connecting wires, push them inside the enclosure and tighten the clamp. Black finish.

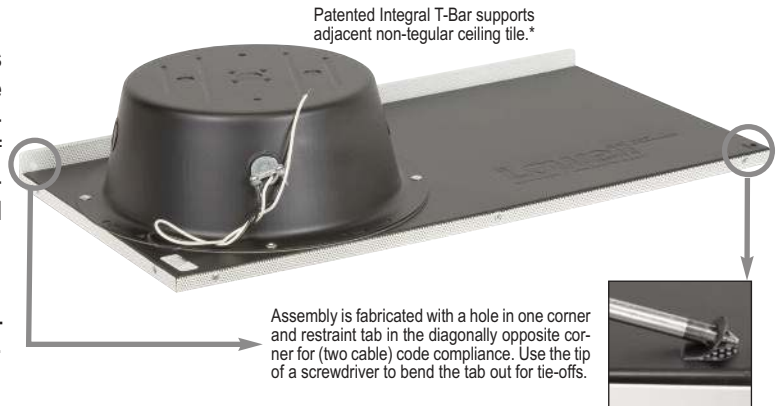

A&E Specifications

The speaker system for suspended tile ceilings shall be Lowell Model No. LT-830-BB. The 1'x2' system shall replace half of a non-regular 2'x2' ceiling tile or one-fourth of a non-regular 2'x4' ceiling tile and shall include an integral T-bar to support adjacent ceiling tile. Each speaker system shall include a factory-mounted driver mounted to a subplate with a fine perforation steel grille finished in white powder epoxy. The driver shall be 8" coaxial with

a power rating of 20W. It shall have a magnet weight of 12 ozs., frequency response of 57Hz-14kHz (± 6 dB), 44Hz-20kHz (± 7.6 dB) and sensitivity of 97.0dB avg. measured 1W/1M. The system shall include a steel backbox (0.147 cu.ft.) with leads exiting through a metal clamp.

Driver Specifications (half space)

Driver No.	Size	Power Rating	Type	Ceramic Magnet	Frequency Response	Dispersion @2000Hz -6dB	Voice Coil Impedance	Voice Coil Diameter	Sensitivity 1W / 1M	Max SPL**	Depth	Weight
CT830A	8"	20W	Coaxial	12 oz.	57Hz-14kHz (± 6 dB) 44Hz-20kHz (± 7.6 dB)	80 degrees conical	8 ohms	1"	97.0dB Avg	110.0dB	3.2"	2.4 lbs.

** Calculated value 1M @ driver power rating.
Additional technical information is available on the spec sheet for driver No. CT830A

* U.S. patent no's. 7,120,269; D467,579; 7,643,647

Heard Everywhere Since 1947

Drawings

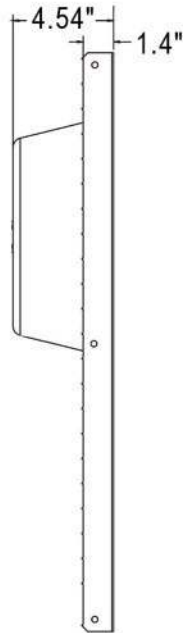
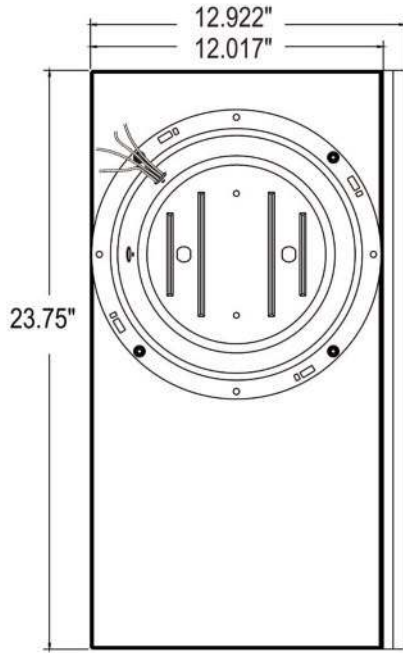

1'x2' installation: Replaces half of a non-regular 2'x2' tile. Integral T-Bar supports non-regular tile that was cut.