

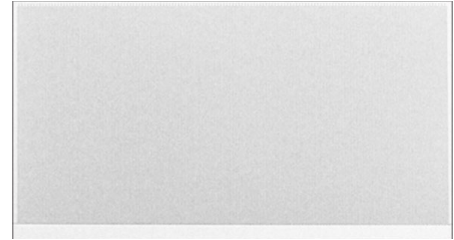

Assembly is fabricated with a hole in one corner and re-straight tab in the diagonally opposite corner for (two cable) code compliance. Use the tip of a screwdriver to bend the tab out for tie-offs.



Patented Integral T-Bar supports adjacent non-regular ceiling tile.*

Quick install speaker system for suspended tile ceilings features an 8" dual cone driver with dual voltage transformer and 1'x 2' fine perforation grille with subplate (infinite baffle). The patented assembly features an integral T-bar support that quickly replaces half of a non-regular 2'x 2' ceiling tile or one-fourth of a non-regular 2'x 4' ceiling tile. For commercial paging and background music.

FEATURES:

- **Driver (810):** 8" 15W dual cone driver with 10 oz. magnet, frequency response of 54Hz-11.6kHz (± 6 dB), 50Hz-20kHz (± 6.6 dB) and sensitivity of 97.9dB avg. measured 1W/1M.
- **Transformer (TLM-572):** Dual voltage transformer (70V/25V) shall feature primary taps at 0.25, 0.5, 1, 2 and 5W.
- **Grille with subplate (1'x 2'):** Fine-perforation grille is designed to provide maximum free-air space for excellent sound transmission while maintaining an unobtrusive appearance in new or existing tile ceilings. Includes an integral 2' T-bar to support neighboring non-regular ceiling tile. Quick install. White finish.

A&E SPECIFICATIONS:

The speaker system for suspended tile ceilings shall be Lowell Model LT-810-72. The 1'x 2' system shall replace half of a non-regular 2'x 2' ceiling tile or one-fourth of a non-regular 2'x 4' ceiling tile and shall include an integral T-bar to support adjacent ceiling tile. Each speaker system shall include a factory-mounted driver with transformer mounted to a subplate with a fine perforation steel grille finished in white powder epoxy. The driver shall be 8" dual cone with a power rating of 15W. It shall have a magnet weight of 10 ozs., frequency response of 54Hz-11.6kHz (± 6 dB); 50Hz-20kHz (± 6.6 dB) and sensitivity of 97.9dB avg. measured 1W/1M. The dual voltage transformer (70/25V) shall feature primary taps at 0.25, 0.5, 1, 2 and 5W.

Driver Specifications: (half space)

Driver No.	Size	Power Rating	Type	Ceramic Magnet	Frequency Response	Dispersion @2000Hz -6dB	Voice Coil Impedance	Voice Coil Diameter	Sensitivity 1W / 1M	Max SPL**	Depth	Weight
810	8"	15W	Dual cone	10 oz.	54Hz-11.6kHz (± 6 dB) 50Hz-20kHz (± 6.6 dB)	95 degrees conical	8 ohms	1"	97.9dB Avg	109.7dB	2.84"	2.0 lbs.

** Calculated value 1M @ driver power rating.

Additional technical information is available on the spec sheet for driver No. 810.

* U.S. patent no's. 7,120,269; D467,579; 7,643,647

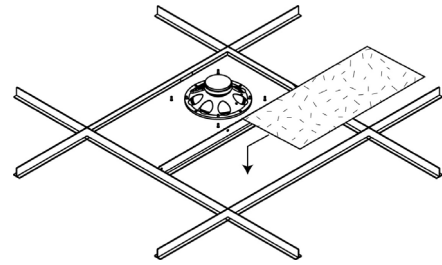
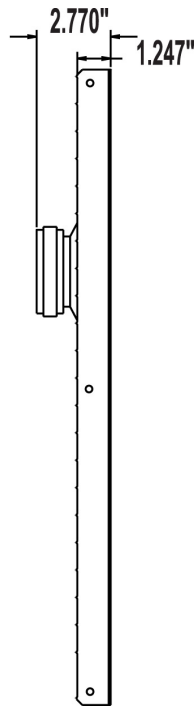
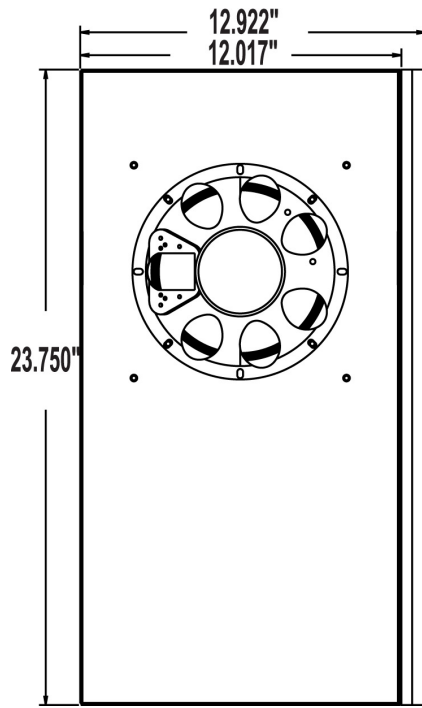

1'x2' installation: Replaces half of a non-regular 2'x2' tile. Integral T-Bar supports non-regular tile that was cut.

