

Steel backbox for recessed installation of an 8" EIA speaker in a ceiling or wall has depth adjustment slots.

FEATURES:

- **Construction:** Welded 18-gauge unitized certified U.S. steel with black powder epoxy finish
- **Dimensions:** 10.00" square
- **Depth:** 6"D
- **Volume:** 0.347 cu.ft.
- **Knockouts:**
 - Four (1/2"–3/4") compound knockouts for conduit
- **Acoustic Treatment:**
 - Foam pad to help reduce acoustic and mechanical resonance
- **Mounting Aids:**
 - Corners have recessed, die-formed mounting tabs with 8-32 screw retaining U-clips for grille installation. The recessed clip position assures protected accessibility in plaster or poured concrete applications.
 - Two sides feature parallel slots (2.688" on 7" centers) to adjust box positioning:
 - When mounting the enclosure to wall studs or pre-mounted 2x4s with screws (not included), place screws in slot centers and slide the enclosure forward or backward until its front edge is flush with the ceiling/wall, then tighten the screws.
 - When mounting the enclosure to a drywall or tile ceiling, use channel rails to support its weight. Attach the enclosure to the rails using the slots to adjust rail positioning so the enclosure sits flush with the ceiling.
- **A&E Specifications:** The enclosure for recessed installation of 8" speakers shall be Lowell model P68X-6, which shall be welded 18-gauge steel with black powder epoxy finish, 10" square 6" deep. Four sides shall feature combination knockouts for conduit (1/2"–3/4"), while two sides shall feature slots for depth adjustment (2.688"L). The enclosure shall have recessed mounting tabs with 8-32 U-clips for grille installation. It shall include a foam pad to help reduce acoustic and mechanical resonance.



INSTALLATION: Recessed
FOR SPEAKER SIZE: 8" EIA
FOR GRILLE TYPE: Screw-mount

COMPATIBLE COMPONENTS (order separately):

- **Speakers:** 8" EIA
- **Speaker+Grille Assemblies:** R7810-72, R7810-72K
- **Grilles (screw-mount):** FW-8, IC-105A, JG-8X, SG-8, SG-8VP
- **Channel Rails:** SS24, SS30, SS48

"P" Series Enclosure Summary

Model No.	For Speaker Size	For Grille Type	Measurements	Depth	Volume (cu.ft.)	Acoustic Treatment	Knockouts	Depth Slots
P625X	4"	Screw-mount	6.25" sq.	4"	0.09 cu.ft.	Undercoated	Side	Yes
P68X	8"	Screw-mount	10.00" sq.	4"	0.231 cu.ft.	Foam pad	Side	Yes
P68X-6	8"	Screw-mount	10.00" sq.	6"	0.347 cu.ft.	Foam pad	Side	Yes
P875X-4	8"	Screw-mount	8.813" sq.	4"	0.180 cu.ft.	Foam pad	Side	Yes
P875X-6	8"	Screw-mount	8.813" sq.	6"	0.270 cu.ft.	Foam pad	Side	Yes

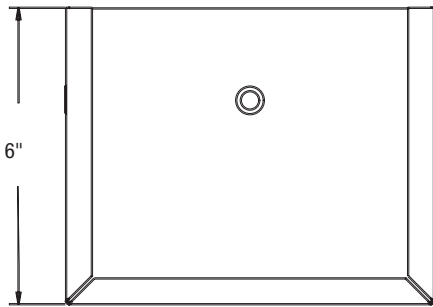
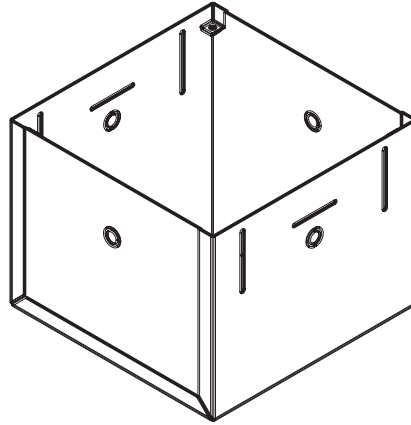
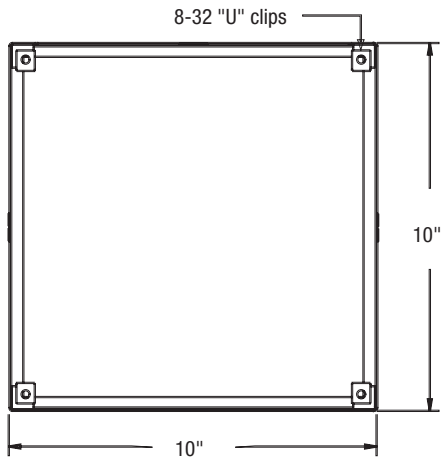

Knockouts on four sides
(1/2"-3/4")

