

Steel enclosure for recessed installation of an 8" EIA speaker in a ceiling or wall has depth adjustment slots.

### FEATURES:

- **Construction:** 20-gauge certified U.S. steel with black powder epoxy finish
- **Dimensions:** 8.813" square
- **Depth:** 6"D
- **Volume:** 0.270 cu.ft.
- **Knockouts:**
  - Four (1/2"–3/4") compound knockouts for conduit
- **Acoustic Treatment:**
  - Foam pad to help reduce acoustic and mechanical resonance
- **Mounting Aids:**
  - Corner has recessed, die-formed mounting tabs with 8-32 screw retaining U-clip for grille installation. Recessed clip position assures protected accessibility in plaster or poured concrete applications.
  - Two sides feature parallel slots (1" on 7" centers) to adjust box positioning:
    - When mounting the enclosure to wall studs or pre-mounted 2x4s with screws (not included), place screws in slot centers and slide the enclosure forward or backward until its front edge is flush with the ceiling/wall, then tighten the screws.
    - When mounting the enclosure to a drywall or tile ceiling, use channel rails to support its weight. Attach the enclosure to the rails using the slots to adjust rail positioning so the enclosure sits flush with the ceiling.
- **A&E Specifications:** The enclosure for recessed installation of 8" speakers shall be Lowell model P875X-6, which shall be 20-gauge steel with black powder epoxy finish, 8.813" square x 6" deep. Four sides shall feature combination knockouts for conduit (1/2"–3/4"), while two sides shall feature slots for depth adjustment (1"L). The enclosure shall have recessed mounting tabs with 8-32 U-clips for grille installation. It shall include a foam pad to help reduce acoustic and mechanical resonance.



**INSTALLATION:** Recessed  
**FOR SPEAKER SIZE:** 8" EIA  
**FOR GRILLE TYPE:** Screw-mount

### COMPATIBLE COMPONENTS (order separately):

- Speakers: 8" EIA
- Horns: LUH Series (only if grille SQLK-8L is used)
- Grilles (screw-mount): FW-8, JG-8X, SQLK-8L
- Channel Rails: SS24, SS30, SS48

### "P" Series Enclosure Summary

Model No.	For Speaker Size	For Grille Type	Measurements	Depth	Volume (cu.ft.)	Acoustic Treatment	Knockouts	Depth Slots
P625X	4"	Screw-mount	6.25" sq.	4"	0.09 cu.ft.	Undercoated	Side	Yes
P68X	8"	Screw-mount	10.00" sq.	4"	0.231 cu.ft.	Foam pad	Side	Yes
P68X-6	8"	Screw-mount	10.00" sq.	6"	0.347 cu.ft.	Foam pad	Side	Yes
P875X-4	8"	Screw-mount	8.813" sq.	4"	0.180 cu.ft.	Foam pad	Side	Yes
<b>P875X-6</b>	<b>8"</b>	<b>Screw-mount</b>	<b>8.813" sq.</b>	<b>6"</b>	<b>0.270 cu.ft.</b>	<b>Foam pad</b>	<b>Side</b>	<b>Yes</b>



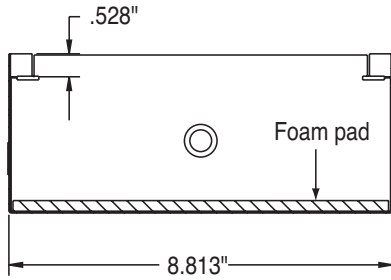
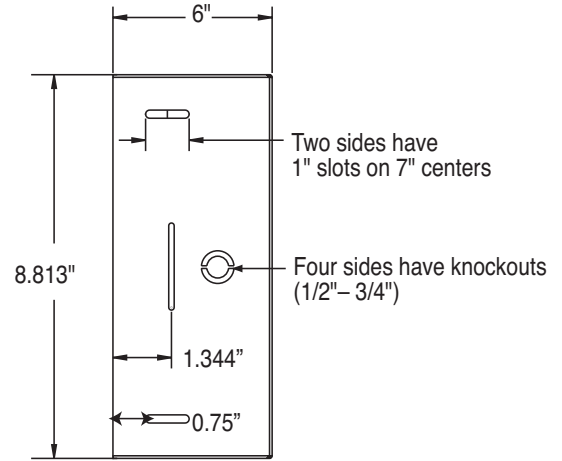
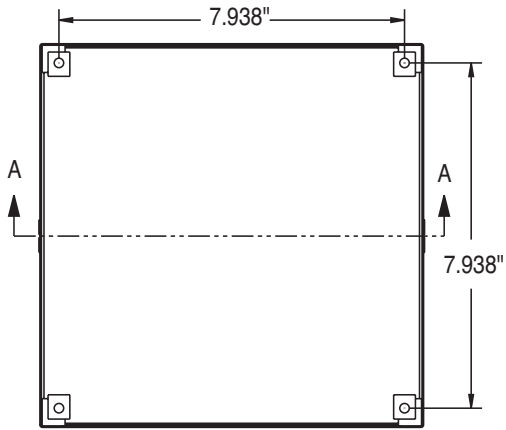

Section A-A

