



Heard Everywhere Since 1947

Spec No. 1224 | Rev. 04.21.15 | pg. 1/3

## Model No. **8C10DVCA-2T72** **8" Cone Driver with 2 voice coils, 2 transformers**

Eight inch (10oz) cone driver with two voice coils for use in commercial, industrial and institutional facilities where individual speakers must be connected to two separate or "piggy-backed" systems. This two circuit, dual-purpose voice paging and signal reproduction approach was popular in older systems so this driver is often specified for replacement purposes. Today most dual-function systems use head-end electronics to perform switching and/or ducking functions between separate paging and music sources. This eliminates dual wiring to the speakers and allows for a more versatile selection of drivers to meet application needs.

### Features

- 15W 8" cone speaker with two voice coils allows for mechanical mixing of two circuits, such as music and paging, at the speaker.
- Highly efficient magnetic structure energized by 10oz ceramic magnet.
- Includes two dual-voltage (70V/25V) transformers with primary taps at 5, 2, 1, .5 and .25 watts
- Frame is stamped 20 gauge steel with a zinc plated finish to prevent corrosion.
- Made in the USA to meet or exceed all applicable EIA standards.

### Application Note

Dual voice coil speakers should not be used when one voice coil is fed from a local (or zoned) sound system. For example, an application where a dual voice coil speaker is installed in a classroom with one voice coil connected to the school's all-call paging system and the other voice coil connected to a local sound system that is used only in that classroom. When the local sound system is playing, the all-call voice coil will also be traveling across the speaker's magnet which induces a small cross-talk voltage on the all-call speaker line. In the speakers in all other classrooms that are connected to the all-call speaker line, this will result in the audio from the local classroom sound system being heard softly. Only use dual voice-coil speakers when all of the speakers on the line are fed by the same two all-call amplifier systems.



### A&E Specifications

The dual voice coil 8 inch driver shall be Lowell Model No. 8C10DVCA-2T72. It shall be of the permanent magnet type with a dual voice coil with dispersion angle of 90 degrees @ 2000Hz (-6dB). Rated power handling capacity shall be 15 watts RMS. Each voice coil shall have a diameter of one inch and operate in a magnetic field derived from a ceramic magnet having a nominal weight of 10oz, and an impedance of 8ohms. The driver shall have a round, stamped 20 gauge steel frame with 8.062 inch diameter, featuring eight obround holes equally spaced on 7.625 inch diameter mounting bolt circle. External metal parts shall be zinc plated. The driver shall include two dual-voltage (70V/25V) factory-wired transformers with primary taps at 5, 2, 1, .5 and .25 watts.

## Specifications (Model No. 8C10DVCA-2T72)

### PERFORMANCE

Driver Power Rating	15 watts RMS (sum of power into both voice coils...7.5 watts per coil)
Driver Impedance (each voice coil)	8 ohms (nominal), minimum 7.6 ohms @342Hz
System Sensitivity (with xfmr)	95.8dB Average SPL (measured 2.83V @ 1m) 102.8dB Maximum SPL (calculated based on maximum 5W power tap and measured sensitivity)
System Frequency Response (with xfmr)	54Hz-9kHz ( $\pm 6$ dB); 50Hz-20kHz ( $\pm 13.4$ dB)
System Dispersion Angle	90 degrees conical @ 2000Hz octave (-6dB)

### PHYSICAL - WOOFER

Magnet Weight, Material	10oz. (264g), strontium ferrite ceramic
Voice Coil Diameter, Material	1 inch (26mm), copper wire
Cone Material	Paper with self edge surround
Terminals	Quick disconnect type - spade lugs

### MECHANICAL

Basket	20 gauge stamped steel with zinc plating
Outside Diameter	8.062 inch (205mm)
Mounting Bolt Circle	7.625 inch (194mm) with 8 obround holes equally spaced at 45 degrees.
Cutout Diameter	7.15 inch (182mm)
Mounting Depth	2.84 inch (72mm)
Net Weight	2.0 lbs. (0.91kg)

### THIELE-SMALL PARAMETERS

Pe.....15 W	Qts .....1.068	BL .....5.2 Tm	Sd .....227 cm <sup>2</sup>
Fs .....86.0 Hz	Qes .....1.219	Efficiency, $\eta$ .....1.56 %	Mms .....8.11 g
Xmax .....0.3 mm	Qms .....8.65	Vas .....30.9 liters	Cms .....423.0 nM/N
Re .....7.5 ohms			

## Scope of Performance & Power Tests

Lowell drivers and loudspeaker systems are tested to provide specifiers and contractors with data that reflects the performance of production products. Testing equipment includes the GoldLine TEF-20 analyzer (for performance measurements) and the LinearX LMS measurement system (for Thiele-Small Parameters).

**Power Rating** is tested based on EIA Standard RS-426B.

**Frequency Response** data is provided which is the measured frequency response range (defined by  $\pm 6$ dB) which is useful in predictive engineering calculations.

**Sensitivity (SPL)** data is presented in two ways: Log Average SPL is a computer calculated log average of the SPL measured at 1 meter with 1 watt input over the stated frequency response range. Maximum SPL is calculated based on the measured log average SPL and the 8-ohm power rating of the speaker. Maximum SPL for loudspeakers which do not include an 8 ohm input, is calculated based on the measured log average SPL and the highest transformer power tap.

**Dispersion Angle** is defined as the angle of coverage that is no more than 6dB down from the on-axis value averaged over the 2000Hz octave band. Since speech intelligibility is very dependent upon the 2000Hz octave, this specification is quite useful in designing speech reinforcement systems that provide even coverage and speech intelligibility.

**Thiele-Small Parameters** for raw drivers are measured using the LinearX LMS measurement system. These parameters are useful in determining the optimum type and size of enclosure for a specific driver.

**Impedance** data is presented in three ways: Nominal Impedance is the generally accepted impedance for use in making comparisons with competitive products, the Impedance Curve is a graphical representation of the impedance that is measured in the lab and gives the impedance of the device over the audio frequency range, Minimum Impedance is the lowest impedance measurement at a frequency within the specified frequency response range of the speaker.

**Polar** data is presented for the averaged one octave band surrounding the center frequencies of 1000Hz, 2000Hz, 4000Hz, and 8000Hz. Radial polar response curves show the relative change in sound pressure level as one moves from directly on-axis to an increasingly off-axis listening position.

## SPL vs. Frequency (including transformer) 1W/1M (half space) On-axis

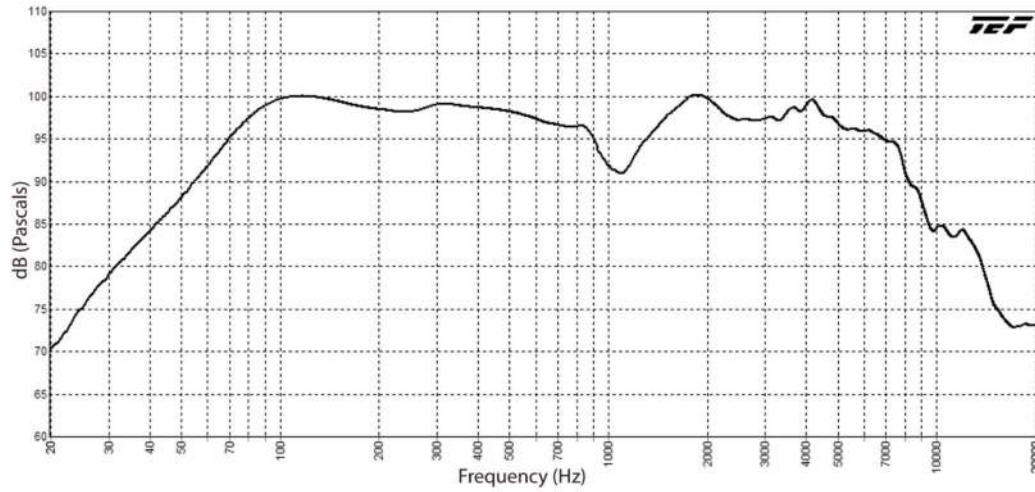

## Polar Data (including transformer) (half space)

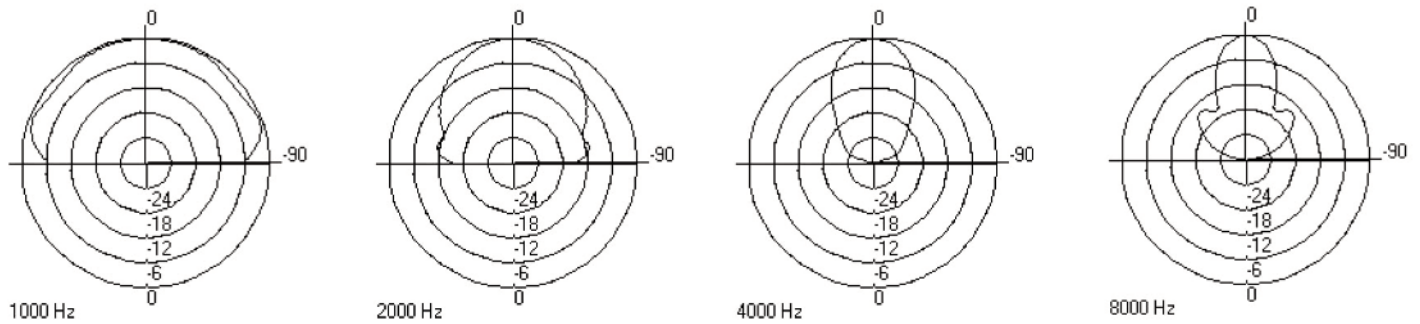

## Impedance (driver voice coil only)

