



### features.

• **Description:** Remote power controls can be combined with a variety of switches or sequencers for an intrinsically safe, low voltage method of controlling AC power to equipment at remote locations. Controlling power distribution without directly accessing equipment minimizes the potential for unauthorized access, while simplifying activation and deactivation of equipment.

*Note: RPCs require an external trigger for activation (order separately).*

• **Chassis:** Steel chassis (7.5"L x 3.25"W x 2.75"H) with black finish and mounting holes.

• **Power:**

- Power Rating: 125VAC 60Hz 20A
- Outlets: NEMA 5-20R duplex
- Hardwired: 1/2" non-metallic flexible conduit (6 ft.)

• **Surge Protection:**

- Maximum Surge Current: 20,000A
- VPR: 400V
- Response Time: 1 nanosecond
- EMI/RFI Noise Reduction: 20dB@100kHz
- Protection Mode: Line to Neutral
- Ground Contamination: None

• **Activation:** The RPC must be connected to an external control for activation and deactivation (choose one):

- Dry Contact Closure (30V 40mA min.): Connect to SPST switch, power sequencer, or independent control system with dry contact closure.
- Voltage Trigger (5-24V AC or DC 5mA): DSP connection.

• **Origin:** Made in the U.S.A. with global components.

• **Third Party Approval:** ETL Listed to UL60065 (U.S. and Canada)

• **Installation:** The RPC is typically installed near the equipment to be controlled. Low voltage cable is run from its terminal strip to a control switch (or other control method).

- Systems can be configured with multiple RPCs controlled by a single "Maintained Closure" switch or voltage trigger source.
- Systems can also be configured with a single RPC controlled by multiple "Momentary Closure" switches and Lowell's MSM2 module (which converts momentary closure to maintained).

• **A&E Specifications:** The device for remotely controlling AC power shall be Lowell model RPC-20-SHW, which shall feature a 7.5"L x 3.25"W x 2.75"H steel chassis with black powder epoxy finish, 125VAC 60Hz 20A power rating, NEMA 5-20R duplex outlet, 6 ft. non-metallic flexible conduit, and basic surge protection up to 20,000A. The unit shall require an external trigger for activation (not included).

• **Compatible Devices:** (order separately)

- **SPST Switch (RPS Series):** Low voltage wall-mount or rack-mount switch:
  - Switch with maintained closure connects directly to RPC.
  - Switch with momentary closure requires Lowell conversion module MSM2 placed between the switch and RPC.

– **Power Sequencer (SEQ Series):** A low voltage sequencer can be used with the RPC for time-delayed activation and deactivation of connected equipment. Lowell standalone sequencers will require a switch for activation, while Lowell rack-mount sequencers include a switch. See product spec sheets for information.

Ideal for Lowell switches featuring maintained closure (order separately):

RPSB-P	Black wall plate w/rocker switch
RPSW-P	White wall plate w/rocker switch
RPSW-KP	White wall plate w/key switch
RPSB-R	Rack panel w/rocker switch
RPSB-KR	Rack panel w/key switch

### RPC Series overview

Model No.	Chassis	Outlets	Input	Power Rating	Surge Suppression	External Activation Required	Connections
RPC-15	Standalone	NEMA 5-15R (2)	6' attached cord	125VAC 60Hz 15A	---	Dry contact closure	Terminal Strip
RPC-15-S	Standalone	NEMA 5-15R (2)	6' attached cord	125VAC 60Hz 15A	Yes	Dry contact closure	Terminal Strip
RPC-15-SCD-RJ	Standalone	NEMA 5-15R (2)	6' attached cord	125VAC 60Hz 15A	Yes	Dry contact closure or VT*	TS or RJ45
RPC-15-U	Standalone	IEC C13 (2)	6' detachable cord (2)	100-240VAC 50/60Hz 15A	---	Dry contact closure or VT*	Terminal Strip
RPC-20-CD	Standalone	NEMA 5-20R (2)	6' attached cord	125VAC 60Hz 20A	---	Dry contact closure or VT*	Terminal Strip
RPC-20-SCD	Standalone	NEMA 5-20R (2)	6' attached cord	125VAC 60Hz 20A	Yes	Dry contact closure or VT*	Terminal Strip
RPC-20-SCD-RJ	Standalone	NEMA 5-20R (2)	6' attached cord	125VAC 60Hz 20A	Yes	Dry contact closure or VT*	TS or RJ45
RPC-3N1	Standalone	NEMA 5-15R (8)	6' attached cord	125VAC 60Hz 15A	---	Dry contact closure	Terminal Strip
RPC-4CD	Rack-mount	NEMA 5-15R (8)	6' attached cord	125VAC 60Hz 15A	---	Dry contact closure	Terminal Strip
RPC-20-HW	Standalone	NEMA 20A (2)	6' flexible whip	125VAC 60Hz 20A	---	Dry contact closure or VT*	Terminal Strip
▶ <b>RPC-20-SHW</b>	<b>Standalone</b>	<b>NEMA 20A (2)</b>	<b>6' flexible whip</b>	<b>125VAC 60Hz 20A</b>	<b>Yes</b>	<b>Dry contact closure or VT*</b>	<b>Terminal Strip</b>
RPC-30-SHW	Standalone	Twistlock 30A (1)	6' flexible whip	125VAC 60Hz 30A	Yes	Dry contact closure or VT*	Terminal Strip

\* VT indicates the RPC can also accept a voltage trigger provided by an independent control system.



**RPC DIAGRAM:**

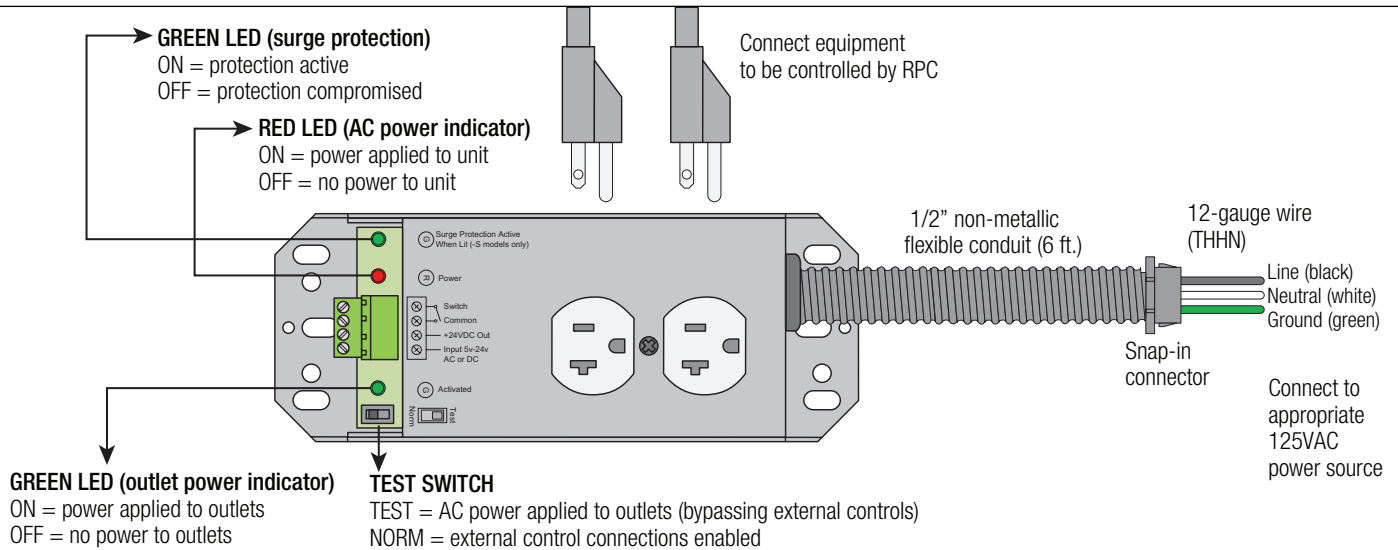

**RPC TYPICAL CONTROL METHODS** (low voltage, limited current Class 2 wiring):

**EXAMPLE 1: SPST switch with MAINTAINED closure.**

See Lowell RPS Series models listed on pg. 1.

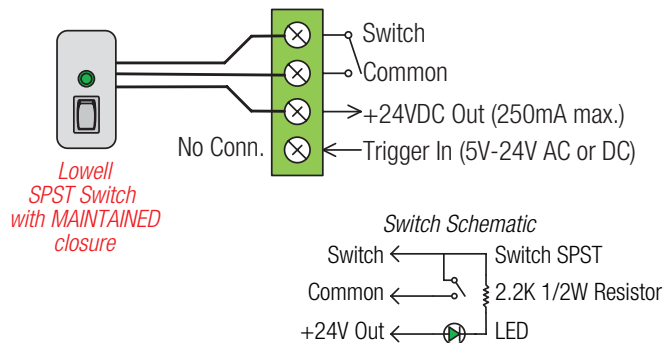

**EXAMPLE 2: Sequencer or Control System.**

Lowell SEQ Series sequencer or control system by others.

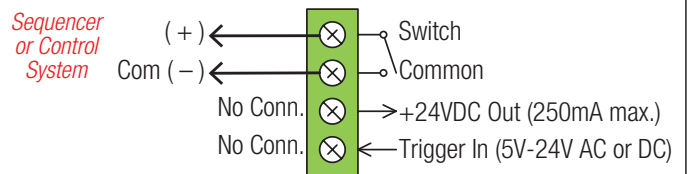

Follow polarity indicators, if any, on sequencer/controller (min. rating: 30V, 40mA)  
ON = connection applied (closed)  
OFF = connection removed (open)

**EXAMPLE 3: Voltage Input.**

Voltage input from external control system (by others).

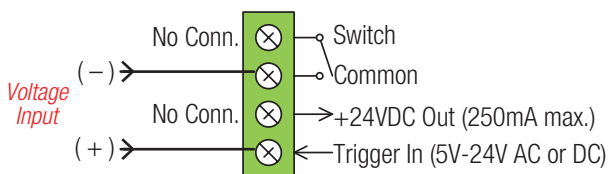

5V-24V, AC or DC, 5mA  
ON = voltage applied  
OFF = voltage removed

**EXAMPLE 4: Fire Alarm Panel Interface.**

Application Example: RPC controls power to music/paging system. A signal from Fire Alarm Panel forces music/paging system OFF so an alarm can be heard.

