



Model No. **LT-410-72-BB** **1x2 Speaker System for Tile Ceilings**

- **Includes 4" driver, transformer, 1x2 grille/subplate, round enclosure**

Quick install speaker system for suspended tile ceilings features a 4" high compliance driver, dual voltage transformer, 1x2 fine perforation grille with subplate, and 0.147 cu.ft. enclosure. The patented assembly features an integral T-bar support that quickly replaces half of a non-regular 2'x2' ceiling tile or one-fourth of a non-regular 2'x4' ceiling tile. Ideal for commercial paging and background music.

Features

- **Driver (JR410):** 4" 15W high-compliance driver with 10 oz. magnet
- **Transformer (TLM-572):** 70/25V transformer with taps at 0.25, 0.5, 1, 2, 5W
- **Grille with subplate (1x2):** Fine-perforation grille is designed to provide maximum free-air space for excellent sound transmission while maintaining an unobtrusive appearance in new or existing tile ceilings. Includes an integral 2' T-bar to support neighboring non-regular ceiling tile. Quick install. White finish.
- **Backbox (8XD4):** 0.147 cu.ft. backbox protects driver assembly. Speaker leads exit through a metal clamp for fast connection—just splice connecting wires, push them inside the enclosure and tighten the clamp. Black finish.

A&E Specifications

The speaker system for suspended tile ceilings shall be Lowell Model No. LT-410-72-BB. The 1'x2' system shall replace half of a non-regular 2'x2' ceiling tile or one-fourth of a non-regular 2'x4' ceiling tile and shall include an integral T-bar to support adjacent ceiling tile. Each speaker system shall include a factory-mounted driver mounted to a subplate with a fine perforation steel grille finished in white powder epoxy. The driver shall be 4" with a power rating of 15W. It shall have a magnet weight of 10 ozs., frequency response of 67Hz-16kHz (± 6 dB); 53Hz-20kHz (± 8 dB) and sensitivity of 90.8dB Avg. meas-

Patented Integral T-Bar supports adjacent non-regular ceiling tile.*

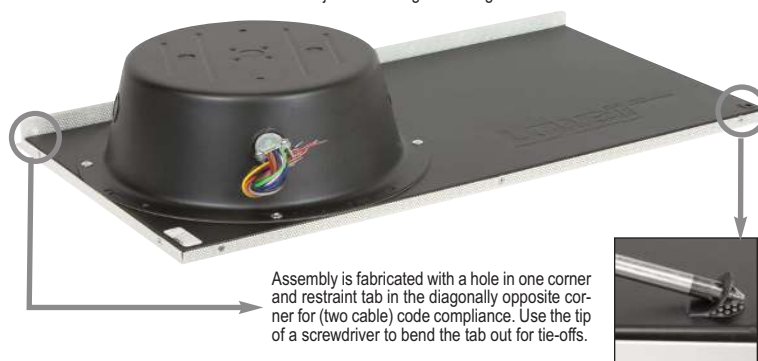

Assembly is fabricated with a hole in one corner and restraint tab in the diagonally opposite corner for (two cable) code compliance. Use the tip of a screwdriver to bend the tab out for tie-offs.



Mounted driver with factory-wired transformer.



Fine perforation pattern grille.

ured 1W/1M. The system shall include a factory-mounted dual voltage (70/25V) transformer with primary taps at 0.25, 0.5, 1, 2, and 5W and a 0.147 cu.ft. steel backbox with black powder epoxy finish. Speaker connections shall exit the enclosure through a metal clamp.

*U.S. patent no's. 7,120,269; D467,579; 7,643,647

Heard Everywhere Since 1947

Drawings

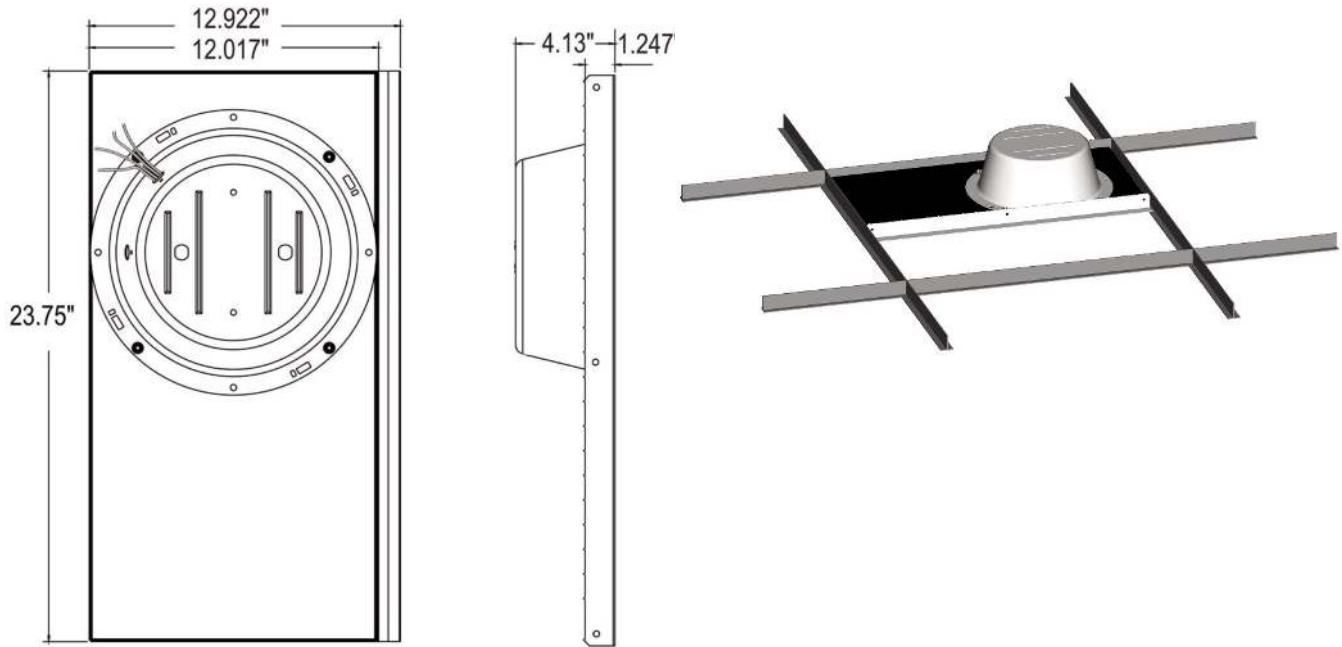

Driver Specifications (half space)

Driver No.	Size	Power Rating	Type	Ceramic Magnet	Frequency Response	Dispersion @2000Hz -6dB	Voice Coil Impedance	Voice Coil Diameter	Sensitivity 1W / 1M	Max SPL*	Depth (w/o xfrm)	Weight (w/o xfrm)
JR410	4"	15W	High compliance	10 oz.	67Hz-16kHz (+6dB) 53Hz-20kHz (+8dB)	170 degrees conical	8 ohms	1"	90.8dB Avg	102.6dB	2.08"	1.7lbs.

*Calculated value 1M @ driver power rating.

Additional technical information is available on the spec sheet for driver No. JR410.