

Mounts 1 or 2 short rack doors to control access to equipment

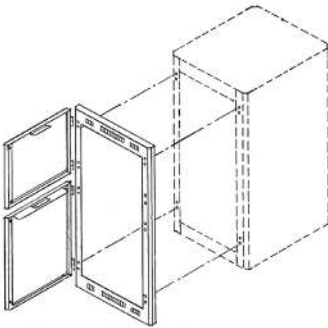

The dual-door frame accepts 1 or 2 short doors, allowing access to some equipment while securing other electronics.



**SECURE:** A bracket keeps contents in bottom space secure when top door is open (bracket projects into rack within 1/4" of mounting rails). Two machine screws are provided for field installation (8-32 x .5"). Factory installed when frame, doors, and rack are ordered together.

### features.

- **Description:**

- The dual-door frame is made to mount short surface-mount doors in order to separate and secure equipment within a single rack. Mount 1 short door to secure some electronics while providing easy access to other equipment, or mount 2 short doors with different key locks to secure each section separately. The LDDF frame is made for 21U–44U racks in the LER, LGR, LPR, LSER, LSGR, and LWR series. Order door(s) separately.

- **Construction:**

- Certified U.S. steel with black powder epoxy finish
- Made in the U.S.A.

- **Features:**

- 1"D frame does not use panel mounting space
- The dual-door frame can be field-installed without drilling or removing pre-wired equipment. The frame is installed at the factory when ordered along with a rack.
- The dual-door frame surface-mounts to top and bottom nutserts on the rack using (4) 10-32 x 5/8" hex washer-head machine screws (included). Back the screws out slightly to allow the frame to mount over screwheads using keyhole slots on the rear.

- A security bracket mounts to the top of the lower door, projecting into rack within 1/4" of mtg. rails to secure the lower section when the top door is opened. The bracket can be field-installed (two screws), changed to mount to the bottom of the upper door, or omitted from the assembly. The bracket is factory-installed when the dual-door frame is ordered with a rack and doors.

*NOTE: Since the bracket extends within 1/4" of mtg. rails, equipment with protruding knobs may need to be repositioned.*

- **Order Separately:**

- **LFD Series (doors):** Solid steel, fully-vented steel or smoked plexiglass surface-mount front door. The chart below indicates what size door to order, depending on its position in the dual-door frame.
- **#LLKRD (alternate key/lock assembly):** If two doors are mounted, the alternate key/lock assembly can be used to change one of the door locks to provide separate security for each section. Field assembly required.

### a&e specifications.

The rack shall be equipped with dual-door frame model \_\_\_\_\_ (#LDDF-21, #LDDF-24, #LDDF-35, #LDDF-40, #LDDF-44), which will accept 1 or 2 short surface-mount front doors to separate and/or secure access to mounted equipment. The surface-mount steel frame shall extend 1" from the rack. It shall attach to factory-installed threaded inserts on the rack, without drilling. Inserts shall be located on right and left to accommodate mounting on either side. The

dual-door frame shall be steel with black powder epoxy paint. The doors and an alternate key lock, if needed, shall be ordered separately.

#### LDDF series summary

Model No.	Description	Accepts Top Door*	Accepts Bottom Door*
LDDF-21	Dual-door frame for 21U rack	7U	14U
LDDF-24	Dual-door frame for 24U rack	10U	14U
LDDF-35	Dual-door frame for 35U rack	14U	21U
LDDF-40	Dual-door frame for 40U rack	16U	24U
LDDF-44	Dual-door frame for 44U rack	21U	24U

\*Order LFD Series door(s) separately according to size indicated in chart. If two doors are used you may want to order an alternate key lock assembly (#LLKRD) for one door for separate access.

